



# ***Service Manual***

## Serial Number Range

**Z-30/20N**

from Z30N08-11500

**Z-30/20N RJ**

**Z-34/22N**

from Z34N07-6291

**Z-34/22DC**

from Z34N07-5427

Part No. 139378

Rev B2

January 2015

---

# Introduction

---

## Important

Read, understand and obey the safety rules and operating instructions in the appropriate Operator's Manual on your machine before attempting any maintenance procedure.

This manual provides detailed scheduled maintenance information for the machine owner and user. It also provides troubleshooting and repair procedures for qualified service professionals.

Basic mechanical, hydraulic and electrical skills are required to perform most procedures. However, several procedures require specialized skills, tools, lifting equipment and a suitable workshop. In these instances, we strongly recommend that maintenance and repair be performed at an authorized Genie dealer service center.

---

## Compliance

### Machine Classification

Group B/Type 3 as defined by ISO 16368

### Machine Design Life

Unrestricted with proper operation, inspection and scheduled maintenance.

---

## Technical Publications

Genie has endeavored to deliver the highest degree of accuracy possible. However, continuous improvement of our products is a Genie policy. Therefore, product specifications are subject to change without notice.

Readers are encouraged to notify Genie of errors and send in suggestions for improvement. All communications will be carefully considered for future printings of this and all other manuals.

---

## Contact Us:

Internet: [www.genielift.com](http://www.genielift.com)  
E-mail: [awp.techpub@terex.com](mailto:awp.techpub@terex.com)

---

## Find a Manual for this Model

Go to <http://www.genielift.com>

Use the links to locate Operator's, Parts or Service Manuals.

---

Copyright © 2011 by Terex Corporation

139378 Rev B2, January 2015

Third Edition, Second Printing

Genie is a registered trademark of Terex South Dakota, Inc. in the U.S.A. and many other countries.

"Z" is a trademark of Terex South Dakota, Inc.



# Introduction

## Revision History

Revision	Date	Section	Procedure / Page / Description
B2	1/2015	Introduction Maint.	Added Revision History Added B-15, Test the Emergency Power
<b>Reference Examples:</b>			<b>Electronic Version</b> Click on any content or procedure in the Table of Contents to view the update.
Section – Maintenance, B-3			
Section – Repair Procedure, 4-2			
Section – Fault Codes, All charts			
Section – Schematics, Legends and schematics			



# Introduction

## Revision History

Revision	Date	Section	Procedure / Page / Description
<b>Reference Examples:</b>			
Section – Maintenance, B-3			
Section – Repair Procedure, 4-2			<b>Electronic Version</b> Click on any content or procedure in the Table of Contents to view the update.
Section – Fault Codes, All charts			
Section – Schematics, Legends and schematics			



# Introduction

## Serial Number Legend



A TEREX BRAND

**Model:** Z-30/20N  
**Serial number:** Z30N05-12345  
**Model year:** 2005 **Manufacture date:** 04/12/05  
**Electrical schematic number:** ESXXXX  
**Machine unladen weight:**

**Rated work load (including occupants):** XXX lb / XXX kg  
**Maximum number of platform occupants:** X  
**Maximum allowable side force :** XXX lb / XXX N  
**Maximum allowable inclination of the chassis:**  
 0 deg  
**Maximum wind speed :** XX mph/ XX m/s  
**Maximum platform height :** XX ft / XX m  
**Maximum platform reach :** XX ft / XX m  
**Gradeability:** N/A  
**Country of manufacture:** USA  
**This machine complies with:**

**Terex South Dakota, Inc.**  
 500 Oak Wood Road  
 PO Box 1150  
 Watertown, SD 57201  
 USA

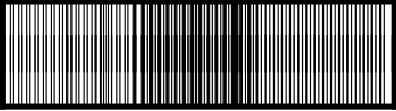

Z30N 05 - 12345

1 2 3

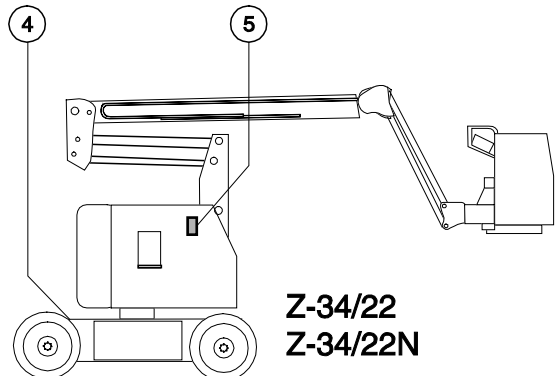
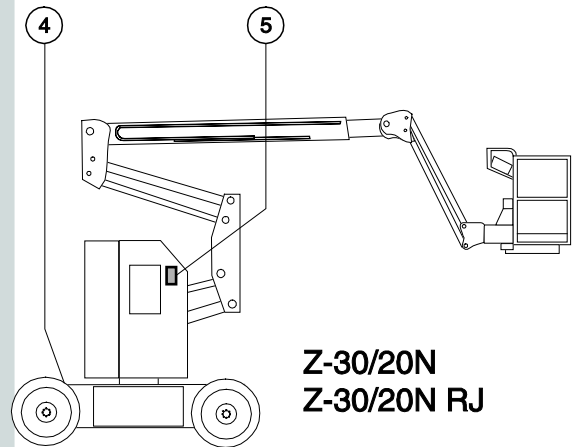

- 1 Model
- 2 Model year
- 3 Sequence number
- 4 Serial number (stamped on chassis)
- 5 Serial label (located under cover)

---

# Safety Rules



## Danger

Failure to obey the instructions and safety rules in this manual and the appropriate Operator's Manual on your machine will result in death or serious injury.

Many of the hazards identified in the operator's manual are also safety hazards when maintenance and repair procedures are performed.

## Do Not Perform Maintenance Unless:

- You are trained and qualified to perform maintenance on this machine.
- You read, understand and obey:
  - manufacturer's instructions and safety rules
  - employer's safety rules and worksite regulations
  - applicable governmental regulations
- You have the appropriate tools, lifting equipment and a suitable workshop.

# Safety Rules

## Personal Safety

Any person working on or around a machine must be aware of all known safety hazards. Personal safety and the continued safe operation of the machine should be your top priority.



Read each procedure thoroughly. This manual and the decals on the machine, use signal words to identify the following:



Safety alert symbol—used to alert personnel to potential personal injury hazards. Obey all safety messages that follow this symbol to avoid possible injury or death.



Indicates a imminently hazardous situation which, if not avoided, will result in death or serious injury.



Indicates a potentially hazardous situation which, if not avoided, could result in death or serious injury.



Indicates a potentially hazardous situation which, if not avoided, may cause minor or moderate injury.



Indicates a potentially hazardous situation which, if not avoided, may result in property damage.



Be sure to wear protective eye wear and other protective clothing if the situation warrants it.



Be aware of potential crushing hazards such as moving parts, free swinging or unsecured components when lifting or placing loads. Always wear approved steel-toed shoes.

## Workplace Safety

Any person working on or around a machine must be aware of all known safety hazards. Personal safety and the continued safe operation of the machine should be your top priority.



Be sure to keep sparks, flames and lighted tobacco away from flammable and combustible materials like battery gases and engine fuels. Always have an approved fire extinguisher within easy reach.



Be sure that all tools and working areas are properly maintained and ready for use. Keep work surfaces clean and free of debris that could get into machine components and cause damage.



Be sure any forklift, overhead crane or other lifting or supporting device is fully capable of supporting and stabilizing the weight to be lifted. Use only chains or straps that are in good condition and of ample capacity.



Be sure that fasteners intended for one time use (i.e., cotter pins and self-locking nuts) are not reused. These components may fail if they are used a second time.



Be sure to properly dispose of old oil or other fluids. Use an approved container. Please be environmentally safe.



Be sure that your workshop or work area is properly ventilated and well lit.

---

# Table of Contents

<b>Introduction</b>	<b>Introduction</b> .....	<b>ii</b>
	Important Information .....	ii
	Find a Manual for this Model.....	ii
	Revision History .....	iii
	Serial Number Legend .....	v
<b>Section 1</b>	<b>Safety Rules</b> .....	<b>vi</b>
	General Safety Rules .....	vi
<b>Section 2</b>	<b>Specifications</b> .....	<b>1</b>
	Machine Specifications .....	1
	Performance Specifications .....	2
	Hydraulic Specification.....	3
	Hydraulic Component Specifications .....	5
	Manifold Component Specifications.....	5
	Machine Torque Specifications .....	6
	Hydraulic Hose and Fitting Torque Specifications .....	7
	Torque Procedure .....	8
SAE and Metric Fasteners Torque Charts.....	10	



# Table of Contents

<b>Section 3</b>	<b>Scheduled Maintenance Procedures</b> .....	<b>11</b>
	Introduction .....	11
	Pre-Delivery Preparation Report .....	14
	Maintenance Inspection Report.....	16
	<b>Checklist A Procedures</b> .....	<b>17</b>
	A-1 Inspect the Manuals and Decals.....	17
	A-2 Perform Pre-operation Inspection.....	18
	A-3 Perform Function Tests .....	18
	A-4 Perform 30 Day Service.....	19
	A-5 Grease the Turntable Rotation Bearing and Worm Drive Gear.....	19
	A-6 Replace the Drive Hub Oil .....	20
	<b>Checklist B Procedures</b> .....	<b>21</b>
	B-1 Inspect the Battery .....	21
	B-2 Inspect the Electrical Wiring .....	22
	B-3 Inspect the Tires, Wheels and Lug Nut Torque .....	23
	B-4 Confirm the Proper Brake Configuration .....	24
	B-5 Check the Drive Hub Oil Level and Fastener Torque.....	24
	B-6 Test the Ground Control Override .....	25
	B-7 Test the Platform Self-leveling.....	26
	B-8 Test the Drive Brakes .....	26
	B-9 Test the Drive Speed - Stowed Position.....	27
	B-10 Test the Drive Speed - Raised or Extended Position .....	28
	B-11 Test the Alarm Package (if equipped) .....	29
	B-12 Test the Turntable Rotation Stop.....	30
	B-13 Check the Electrical Contactors .....	30
	B-14 Perform Hydraulic Oil Analysis .....	31
	B-15 Test the Emergency Power System .....	31



## Table of Contents

	<b>Checklist C Procedures</b> .....	<b>33</b>
	C-1 Grease the Platform Overload Mechanism (if equipped).....	33
	C-2 Test the Platform Overload System (if equipped).....	33
	<b>Checklist D Procedures</b> .....	<b>35</b>
	D-1 Check the Boom Wear Pads.....	35
	D-2 Check the Free-wheel Configuration.....	36
	D-3 Check the Turntable Rotation Bearing Bolts.....	37
	D-4 Replace the Drive Hub Oil.....	38
	D-5 Replace the Hydraulic Tank Return Filter Element.....	38
	D-6 Inspect for Turntable Bearing Wear.....	39
	<b>Checklist E Procedures</b> .....	<b>41</b>
	E-1 Test or Replace the Hydraulic Oil.....	41
	E-2 Grease the Steer Axle Wheel Bearings.....	43
<b>Section 4</b>	<b>Repair Procedures</b> .....	<b>45</b>
	Introduction.....	45
	<b>Platform Controls</b> .....	<b>47</b>
	1-1 Controllers.....	47
	<b>Platform Components</b> .....	<b>49</b>
	2-1 Platform Leveling Slave Cylinder.....	49
	2-2 Platform Rotator.....	50
	2-3 Platform Overload System.....	51
	<b>Jib Boom Components</b> .....	<b>54</b>
	3-1 Platform Overload System.....	54
	3-2 Jib Boom Bell Crank (models without rotating jib boom).....	55
	3-3 Jib Boom Bell Crank (models with rotating jib boom).....	56
	3-4 Jib Boom Lift Cylinder.....	58

# Table of Contents

<b>Primary Boom Components</b> .....	<b>59</b>
4-1 Cable Track.....	59
4-2 Primary Boom.....	60
4-3 Primary Boom Lift Cylinder .....	63
4-4 Primary Boom Extension Cylinder .....	65
4-5 Platform Leveling Master Cylinder .....	67
<b>Secondary Boom Components</b> .....	<b>68</b>
5-1 Secondary Boom.....	69
5-2 Secondary Boom Lift Cylinders.....	74
<b>Hydraulic Pump</b> .....	<b>77</b>
6-1 Auxiliary and Function Pump .....	77
<b>Manifolds</b> .....	<b>78</b>
7-1 Function Manifold Components .....	78
7-2 Valve Adjustments - Function Manifold.....	82
7-3 Jib Boom and Platform / Jib Boom Rotate Manifold Components.....	85
7-4 Valve Coils .....	87
<b>Turntable Rotation Components</b> .....	<b>90</b>
8-1 Turntable Rotation Hydraulic Motor .....	90
<b>Steer Axle Components</b> .....	<b>91</b>
9-1 Hub and Bearings .....	91
<b>Non-steer Axle Components</b> .....	<b>93</b>
10-1 Motor Controller .....	93



---

## Table of Contents

<b>Section 5</b>	<b>Fault Codes</b> .....	<b>94</b>
	Introduction .....	94
<b>Section 6</b>	<b>Schematics</b> .....	<b>99</b>
	Introduction .....	99
	Electrical Symbol Legend .....	100
	Hydraulic Symbols Legend .....	101
	Limit Switch Location Legend .....	102
	<b>Electrical Schematics – Options</b> .....	<b>103</b>
	Power Cable Wiring Diagram.....	104
	Drive Contactor Panel Wiring Diagram.....	105
	Manifold and Limit Switch Wiring Diagram .....	108
	LVI/BCI Option Wiring Diagram .....	109
	Charger Interlock Option.....	112
	CTE Option, (CE Models) .....	113
	<b>Hydraulic Schematics</b> .....	<b>115</b>
	Hydraulic Schematic .....	116

---

## Table of Contents

<b>Electrical Schematics – ANSI / CSA / AS Models.....</b>	<b>117</b>
Electrical Schematic, (ANSI / CSA / AS), (before serial numbers Z30N10-12119, Z34N10-8857 and Z3410-7774).....	118
Ground Control Box Terminal Strip Wiring Diagram, (ANSI / CSA / AS), (before serial numbers Z3010-12119, Z34N10-8857 and Z3410-7774).....	119
Ground Control Box Terminal Strip Wiring Diagram, (ANSI / CSA / AS), (before serial numbers Z3010-12119, Z34N10-8857 and Z3410-7774).....	122
Ground Control Box Switch Panel Wiring Diagram, (ANSI / CSA / AS), (before serial numbers Z30N10-12119, Z34N10-8857 and Z3410-7774).....	123
Platform Control Box Wiring Diagram, (ANSI / CSA / AS), (before serial numbers Z30N10-12119, Z34N10-8857 and Z3410-7774).....	126
<b>Electrical Schematics – CE Models .....</b>	<b>127</b>
Electrical Schematic, (CE), (before serial numbers Z30N10-12119, Z34N10-8857 and Z3410-7774).....	128
Ground Control Box Terminal Strip Wiring Diagram, (CE), (before serial numbers Z30N10-12119, Z34N10-8857 and Z3410-7774).....	132
Ground Control Box Switch Panel Wiring Diagram, (CE), (before serial numbers Z30N10-12119, Z34N10-8857 and Z3410-7774).....	133
Platform Control Box Wiring Diagram, (CE), (before serial numbers Z30N10-12119, Z34N10-8857 and Z3410-7774).....	136

---

## Table of Contents

<b>Electrical Schematics – ANSI and CSA Models</b> .....	<b>137</b>
Electrical Schematic, (ANSI / CSA), (from serial numbers Z30N10-12119, Z34N10-8857 and Z3410-7774).....	138
Ground Control Box Terminal Strip Wiring Diagram, (ANSI / CSA), (from serial numbers Z30N10-12119, Z34N10-8857 and Z3410-7774) .....	142
Ground Control Box Switch Panel Wiring Diagram, (ANSI / CSA), (from serial numbers Z30N10-12119, Z34N10-8857 and Z3410-7774) .....	143
Platform Control Box Wiring Diagram, (ANSI / CSA), (from serial numbers Z30N10-12119, Z34N10-8857 and Z3410-7774) .....	146
<b>Electrical Schematics – AS / CE Models</b> .....	<b>147</b>
Electrical Schematic, (AS / CE), (from serial numbers Z30N10-12119, Z34N10-8857 and Z3410-7774).....	148
Ground Control Box Terminal Strip Wiring Diagram, (AS / CE), (from serial numbers Z30N10-12119, Z34N10-8857 and Z3410-7774) .....	152
Ground Control Box Switch Panel Wiring Diagram, (AS / CE), (from serial numbers Z30N10-12119, Z34N10-8857 and Z3410-7774) .....	153
Platform Control Box Wiring Diagram, (AS / CE), (from serial numbers Z30N10-12119, Z34N10-8857 and Z3410-7774) .....	156

# Specifications

## Machine Specifications

### Tires and wheels, Z-30/20N, Z-30/20N RJ and Z-34/22N

Tire size (solid rubber)	22 x 7 x 17.5 in 56 x 18 x 44 cm
Load range	7600 lbs 3447 kg
Overall tire diameter	22 in 56 cm
Wheel diameter	17.5 in 44 cm
Wheel width	7 in 18 cm

### Tires and wheels, Z-34/22

Tire size	9-14.5 LT
Tire ply rating	12
Tire weight, new foam-filled (minimum)	175 lbs 79 kg
Overall tire diameter	28 in 71 cm
Wheel diameter	14.5 in 37 cm
Wheel width	7 in 18 cm

### Wheel lugs

Front	8 @ 5/8 -18
Rear	9 @ 5/8 -18
Lug nut torque, dry	125 ft-lbs 169.5 Nm
Lug nut torque, lubricated	95 ft-lbs 129 Nm

### Fuel capacities

Hydraulic tank	4 gallons 15.1 liters
Hydraulic system (including tank)	6 gallons 22.7 liters

### Drive hubs

48:1	24.5 fl oz/0.72 liters
57:1	24.5 fl oz/0.72 liters

Drive hub oil type: SAE 90 multipurpose hypoid gear oil  
API service classification GL5

**For operational specifications, refer to the Operator's Manual.**

**Continuous improvement of our products is a Genie policy. Product specifications are subject to change without notice or obligation.**

## Specifications

### Performance Specifications Z-30/20N and Z-30/20N RJ

#### Drive speed, maximum

Stowed position	4.5 mph 7.2 km/h 40 ft / 6.0 sec 12.2 m / 6.0 sec
-----------------	--

Boom raised or extended	0.6 mph 1 km/h 40 ft / 42 sec 12.2 m / 42 sec
-------------------------	--

#### Braking distance, maximum

High range on paved surface	2 to 4 ft 0.6 to 1.2m
-----------------------------	--------------------------

<b>Gradeability</b>	See Operator's Manual
---------------------	--------------------------

#### Boom function speeds, maximum from platform controls (with rated load secured to platform)

Jib boom up	19 to 23 seconds
Jib boom down	17 to 21 seconds
Jib boom rotate, 180°	13 to 17 seconds
Primary boom up	14 to 22 seconds
Primary boom down	12 to 20 seconds
Primary boom extend	15 to 19 seconds
Primary boom retract	10 to 14 seconds
Secondary boom up	11 to 18 seconds
Secondary boom down	7 to 15 seconds
Turntable rotate, 355°	62 to 68 seconds
Platform rotate, 180°	5 to 11 seconds
Platform level up	14 to 19 seconds
Platform level down	13 to 18 seconds

### Performance Specifications Z-34/22 and Z-34/22N

#### Drive speed, maximum

Stowed position	4.5 mph 7.2 km/h 40 ft / 6.0 sec 12.2 m / 6.0 sec
-----------------	--

Boom raised or extended	0.6 mph 1 km/h 40 ft / 42 sec 12.2 m / 42 sec
-------------------------	--

#### Braking distance, maximum

High range on paved surface	2 to 4 ft 0.6 to 1.2m
-----------------------------	--------------------------

<b>Gradeability</b>	See Operator's Manual
---------------------	--------------------------

#### Boom function speeds, maximum from platform controls (with rated load secured to platform)

Jib boom up	20 to 24 seconds
Jib boom down	18 to 22 seconds
Primary boom up	16 to 22 seconds
Primary boom down	13 to 20 seconds
Primary boom extend	11 to 15 seconds
Primary boom retract	13 to 17 seconds
Secondary boom up	15 to 22 seconds
Secondary boom down	11 to 18 seconds
Turntable rotate, 355°	62 to 68 seconds
Platform rotate, 180°	5 to 11 seconds
Platform level up	14 to 19 seconds
Platform level down	13 to 18 seconds

**Continuous improvement of our products is a Genie policy. Product specifications are subject to change without notice or obligation.**



# Specifications

## Hydraulic Specifications

### Hydraulic Fluid Specifications

Genie specifications require hydraulic oils which are designed to give maximum protection to hydraulic systems, have the ability to perform over a wide temperature range, and the viscosity index should exceed 140. They should provide excellent antiwear, oxidation prevention, corrosion inhibition, seal conditioning, and foam and aeration suppression properties.

Cleanliness level, minimum	ISO 15/13
Water content, maximum	250 ppm

### Recommended Hydraulic Fluid

Hydraulic oil type	Chevron Rando HD Premium
Viscosity grade	32
Viscosity index	200

### Optional Hydraulic Fluids

Mineral based	Shell Tellus S2 V 32
	Shell Tellus S2 V 46
	Chevron 5606A
Biodegradable	Petro Canada Environ MV 46
Fire resistant	UCON Hydrolube HP-5046

Note: Genie specifications require additional equipment and special installation instructions for the approved optional fluids. Consult Genie Product Support before use.

**NOTICE** Optional fluids may not have the same hydraulic lifespan and may result in component damage.

Note: Extended machine operation can cause the hydraulic fluid temperature to increase beyond it's maximum allowable range. If the hydraulic fluid temperature consistently exceeds 200°F / 90°C an optional oil cooler may be required.

### NOTICE

Do not top off with incompatible hydraulic fluids. Hydraulic fluids may be incompatible due to the differences in base additive chemistry. When incompatible fluids are mixed, insoluble materials may form and deposit in the hydraulic system, plugging hydraulic lines, filters, control valves and may result in component damage.

Note: Do not operate the machine when the ambient air temperature is consistently above 120°F / 49°C.

## Hydraulic Fluid Temperature Range

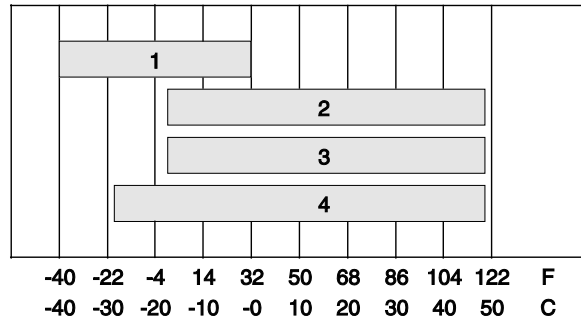

Ambient air temperature

- 1 Chevron hydraulic oil 5606A
- 2 Petro-Canada Environ MV 46
- 3 UCON Hydrolube HP-5046D
- 4 Chevron Rando HD premium oil MV

## Specifications

### Chevron Rando HD Premium Oil MV Fluid Properties

ISO Grade	32
Viscosity index	200
Kinematic Viscosity cSt @ 200°F / 100°C	7.5
cSt @ 104°F / 40°C	33.5
Brookfield Viscosity cP @ -4°F / -20°C	1040
cP @ -22°F / -30°C	3310
Flash point	375°F / 190°C
Pour point	-58°F / -50°C
Maximum continuous operating temperature	171°F / 77°C

Note: An hydraulic oil heating system is recommended when the ambient temperature is consistently below 0°F / -18°C.

Note: Do not operate the machine when the ambient temperature is below -20°F / -29°C with Rando HD Premium MV.

### Chevron 5606A Hydraulic Oil Fluid Properties

ISO Grade	15
Viscosity index	300
Kinematic Viscosity cSt @ 200°F / 100°C	5.5
cSt @ 104°F / 40°C	15.0
cSt @ -40°F / -40°C	510
Flash point	180°F / 82°C
Pour point	-81°F / -63°C
Maximum continuous operating temperature	124°F / 51°C

Note: Use of Chevron 5606A hydraulic fluid, or equivalent, is required when ambient temperatures are consistently below 0°F / -17°C unless an oil heating system is used.

### NOTICE

Continued use of Chevron 5606A hydraulic fluid, or equivalent, when ambient temperatures are consistently above 32°F / 0°C may result in component damage

### Petro-Canada Environ MV 46 Fluid Properties

ISO Grade	46
Viscosity index	154
Kinematic Viscosity cSt @ 200°F / 100°C	8.0
cSt @ 104°F / 40°C	44.4
Flash point	482°F / 250°C
Pour point	-49°F / -45°C
Maximum continuous operating temperature	180°F / 82°C

### UCON Hydrolube HP-5046 Fluid Properties

ISO Grade	46
Viscosity index	192
Kinematic Viscosity cSt @ 149°F / 65°C	22
cSt @ 104°F / 40°C	46
cSt @ 0°F / -18°C	1300
Flash point	None
Pour point	-81°F / -63°C
Maximum continuous operating temperature	189°F / 87°C

**Continuous improvement of our products is a Genie policy. Product specifications are subject to change without notice or obligation.**

# Specifications

## Hydraulic Component Specifications

### Function pump

Type: Fixed displacement gear pump

Displacement 0.183 cu in  
3 cc

Flow rate @2800 psi / 172 bar 2.1 gpm  
7.9 L/min

Hydraulic tank return filter 10 micron with 25 psi /  
1.7 bar bypass

### Function manifold

System relief valve pressure,  
Z-30/20N and Z-30/20N RJ 2800 psi  
193 bar

System relief valve pressure,  
Z-34/22 and Z-34/22N 3200 psi  
221 bar

Primary boom down relief pressure 1600 psi  
110 bar

Secondary boom down relief pressure 1600 psi  
110 bar

Primary boom extend relief pressure 1800 psi  
Models with rotating jib 124 bar

Turntable rotate relief pressure 1100 psi  
76 bar

### Auxiliary pump

Type: Fixed displacement gear pump

Displacement 0.3 gpm  
1.14 L/min

**Continuous improvement of our products is a Genie policy. Product specifications are subject to change without notice or obligation.**

## Manifold Component Specifications

### Plug torque

SAE No. 2 36 in-lbs / 4 Nm

SAE No. 4 10 ft-lbs / 13 Nm

SAE No. 6 14 ft-lbs / 19 Nm

SAE No. 8 38 ft-lbs / 51 Nm

SAE No. 10 41 ft-lbs / 55 Nm

SAE No. 12 56 ft-lbs / 76 Nm

### Valve Coil Resistance

Note: The following coil resistance specifications are at an ambient temperature of 68°F / 20°C. As valve coil resistance is sensitive to changes in air temperature, the coil resistance will typically increase or decrease by 4% for each 18°F / 10°C that your air temperature increases or decreases from 68°F / 20°C.

### Valve Coil Resistance Specification

Description	Specification
Solenoid valve, 3 position 4 way, 20V DC (schematic items A, J, K, U, V, Y, AA, AB and CC)	22 Ω
Proportional solenoid valve, 24V DC (schematic item H)	19.5 Ω
Solenoid valve, N.C. poppet, 20V DC (schematic item M)	23.5 Ω
Solenoid valve, N.O. poppet, 20V DC (schematic item P)	23.5 Ω

# Specifications

## Machine Torque Specifications

### Platform rotator and jib boom rotator (Z-30/20N RJ)

1-8 center bolt, GR 5, lubricated (Jib boom rotator)	480 ft-lbs 650 Nm
3/4 -10 bolt, GR 8, lubricated (Platform rotator)	280 ft-lbs 379 Nm
3/8 -16 bolts, GR 8, lubricated (Platform rotator)	23 ft-lbs 31 Nm
1/2 -13 bolts, GR 5, lubricated (Jib boom rotator)	57 ft-lbs 77 Nm

### Platform rotator (Z-30/20N, Z-34/22 and Z-34/22N)

3/4 -10 bolt, GR 8, lubricated	280 ft-lbs 379 Nm
3/8 -16 bolts, GR 8, lubricated	23 ft-lbs 31 Nm

### Turntable rotate bearing

Rotate bearing mounting bolts, lubricated	180 ft-lbs 244 Nm
---	----------------------

### Drive hubs, brakes and motors

Drive hub mounting bolts, lubricated	180 ft-lbs 244 Nm
Brake mounting bolts, lubricated	93 ft-lbs 126 Nm
Drive motor mounting bolts	31 ft-lbs 42 Nm

**Continuous improvement of our products is a Genie policy. Product specifications are subject to change without notice or obligation.**

## Specifications

### Hydraulic Hose and Fitting Torque Specifications

Your machine is equipped with Parker Seal-Lok™ ORFS or 37° JIC fittings and hose ends. Genie specifications require that fittings and hose ends be torqued to specification when they are removed and installed or when new hoses or fittings are installed.

Seal-Lok™ Fittings (hose end - ORFS)	
SAE Dash Size	Torque
-4	10 ft-lbs / 13.6 Nm
-6	30 ft-lbs / 40.7 Nm
-8	40 ft-lbs / 54.2 Nm
-10	60 ft-lbs / 81.3 Nm
-12	85 ft-lbs / 115 Nm
-16	110 ft-lbs / 150 Nm
-20	140 ft-lbs / 190 Nm
-24	180 ft-lbs / 245 Nm

JIC 37° Fittings (swivel nut or hose connection)		
SAE Dash Size	Thread Size	Flats
-4	7/16-20	2
-6	9/16-18	1 ¼
-8	3/4-16	1
-10	7/8-14	1
-12	1 1/16-12	1
-16	1 5/16-12	1
-20	1 5/8-12	1
-24	1 7/8-12	1

SAE O-ring Boss Port (tube fitting - installed into Aluminum) (all types)	
SAE Dash Size	Torque
-4	14 ft-lbs / 19 Nm
-6	23 ft-lbs / 31.2 Nm
-8	36 ft-lbs / 54.2 Nm
-10	62 ft-lbs / 84 Nm
-12	84 ft-lbs / 114 Nm
-16	125 ft-lbs / 169.5 Nm
-20	151 ft-lbs / 204.7 Nm
-24	184 ft-lbs / 249.5 Nm

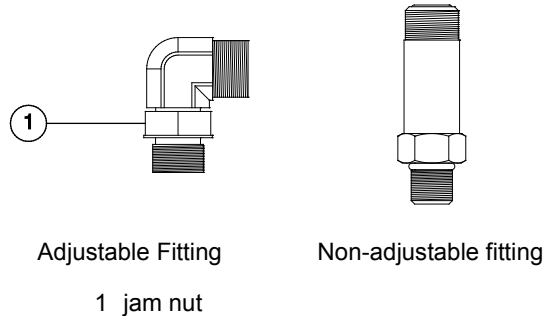

SAE O-ring Boss Port (tube fitting - installed into Steel)		
SAE Dash Size		Torque
-4	ORFS / 37° (Adj)	15 ft-lbs / 20.3 Nm
	ORFS (Non-adj)	26 ft-lbs / 35.3 Nm
	37° (Non-adj)	22 ft-lbs / 30 Nm
-6	ORFS (Adj / Non-adj)	35 ft-lbs / 47.5 Nm
	37° (Adj / Non-adj)	29 ft-lbs / 39.3 Nm
-8	ORFS (Adj / Non-adj)	60 ft-lbs / 81.3 Nm
	37° (Adj / Non-adj)	52 ft-lbs / 70.5 Nm
-10	ORFS (Adj / Non-adj)	100 ft-lbs / 135.6 Nm
	37° (Adj / Non-adj)	85 ft-lbs / 115.3 Nm
-12	(All types)	135 ft-lbs / 183 Nm
-16	(All types)	200 ft-lbs / 271.2 Nm
-20	(All types)	250 ft-lbs / 339 Nm
-24	(All types)	305 ft-lbs / 413.5 Nm

# Specifications

## Torque Procedure

### Seal-Lok™ fittings

- 1 Replace the O-ring. The O-ring must be replaced anytime the seal has been broken. The O-ring cannot be re-used if the fitting or hose end has been tightened beyond finger tight.

Note: The O-ring in Parker Seal Lok™ fittings and hose end are custom-size O-rings. They are not standard size O-rings. They are available in the O-ring field service kit (Genie part number 49612).

- 2 Lubricate the O-ring before installation.
- 3 Be sure the O-ring face seal is seated and retained properly.
- 4 Position the tube and nut squarely on the face seal end of the fitting, and tighten the nut finger tight.
- 5 Tighten the nut or fitting to the appropriate torque. Refer to the appropriate torque chart in this section.
- 6 Operate all machine functions and inspect the hose, fittings and related components to confirm there are no leaks.

### JIC 37° fittings

- 1 Align the tube flare (hex nut) against the nose of the fitting body (body hex fitting) and tighten the hex nut to the body hex fitting to hand tight, approximately 30 in-lbs / 3.4 Nm.
- 2 Using a permanent ink marker, make a reference mark on one the flats of the hex nut and continue the mark onto the body of the hex fitting. Refer to Illustration 1.

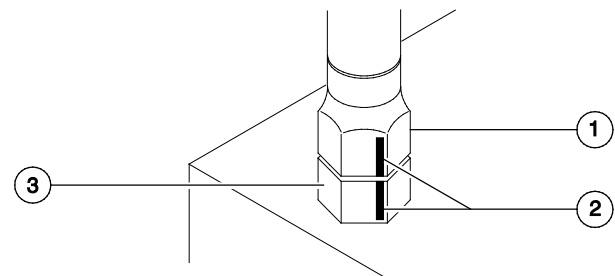

Illustration 1

- 1 hex nut
- 2 reference mark
- 3 body hex fitting

## Specifications

- 3 Working clockwise on the body hex fitting, make a second mark with a permanent ink marker to indicate the proper tightening position. Refer to Illustration 2.

Note: Use the JIC 37° Fitting table in this section to determine the correct number of flats, for the proper tightening position.

Note: The marks indicate the correct tightening positions have been determined. Use the second mark on the body hex fitting to properly tighten the joint after it has been loosened.

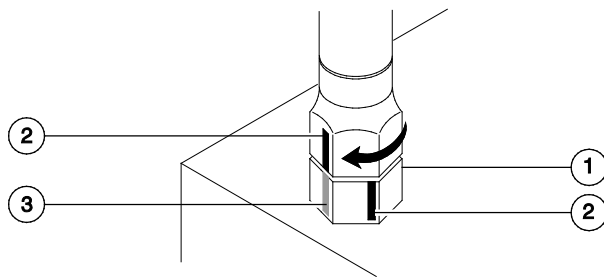







Illustration 2

- 1 body hex fitting
- 2 reference mark
- 3 second mark

- 4 Tighten the hex nut until the mark on the hex nut is aligned with the second mark on the body hex fitting.
- 5 Operate all machine functions and inspect the hose, fittings and related components to confirm there are no leaks.

# Specifications

<b>SAE FASTENER TORQUE CHART</b>											
• This chart is to be used as a guide only unless noted elsewhere in this manual •											
SIZE	THREAD	Grade 5 				Grade 8 				A574 High Strength Black Oxide Bolts	
		LUBED		DRY		LUBED		DRY		LUBED	
		in-lbs	Nm	in-lbs	Nm	in-lbs	Nm	in-lbs	Nm	in-lbs	Nm
1/4	20	80	9	100	11.3	110	12.4	140	15.8	130	14.7
	28	90	10.1	120	13.5	120	13.5	160	18	140	15.8
		LUBED		DRY		LUBED		DRY		LUBED	
		ft-lbs	Nm	ft-lbs	Nm	ft-lbs	Nm	ft-lbs	Nm	ft-lbs	Nm
5/16	18	13	17.6	17	23	18	24	25	33.9	21	28.4
	24	14	19	19	25.7	20	27.1	27	36.6	24	32.5
3/8	16	23	31.2	31	42	33	44.7	44	59.6	38	51.5
	24	26	35.2	35	47.4	37	50.1	49	66.4	43	58.3
7/16	14	37	50.1	49	66.4	50	67.8	70	94.7	61	82.7
	20	41	55.5	55	74.5	60	81.3	80	108.4	68	92.1
1/2	13	57	77.3	75	101.6	80	108.4	110	149	93	126
	20	64	86.7	85	115	90	122	120	162	105	142
9/16	12	80	108.4	110	149	120	162	150	203	130	176
	18	90	122	120	162	130	176	170	230	140	189
5/8	11	110	149	150	203	160	217	210	284	180	244
	18	130	176	170	230	180	244	240	325	200	271
3/4	10	200	271	270	366	280	379	380	515	320	433
	16	220	298	300	406	310	420	420	569	350	474
7/8	9	320	433	430	583	450	610	610	827	510	691
	14	350	474	470	637	500	678	670	908	560	759
1	8	480	650	640	867	680	922	910	1233	770	1044
	12	530	718	710	962	750	1016	990	1342	840	1139
1 1/8	7	590	800	790	1071	970	1315	1290	1749	1090	1477
	12	670	908	890	1206	1080	1464	1440	1952	1220	1654
1 1/4	7	840	1138	1120	1518	1360	1844	1820	2467	1530	2074
	12	930	1260	1240	1681	1510	2047	2010	2725	1700	2304
1 1/2	6	1460	1979	1950	2643	2370	3213	3160	4284	2670	3620
	12	1640	2223	2190	2969	2670	3620	3560	4826	3000	4067

<b>METRIC FASTENER TORQUE CHART</b>																
• This chart is to be used as a guide only unless noted elsewhere in this manual •																
Size (mm)	Class 4.6 				Class 8.8 				Class 10.9 				Class 12.9 			
	LUBED		DRY		LUBED		DRY		LUBED		DRY		LUBED		DRY	
	in-lbs	Nm	in-lbs	Nm	in-lbs	Nm	in-lbs	Nm	in-lbs	Nm	in-lbs	Nm	in-lbs	Nm	in-lbs	Nm
5	16	1.8	21	2.4	41	4.63	54	6.18	58	6.63	78	8.84	68	7.75	91	10.3
6	19	3.05	36	4.07	69	7.87	93	10.5	100	11.3	132	15	116	13.2	155	17.6
7	45	5.12	60	6.83	116	13.2	155	17.6	167	18.9	223	25.2	1.95	22.1	260	29.4
	LUBED		DRY		LUBED		DRY		LUBED		DRY		LUBED		DRY	
	ft-lbs	Nm	ft-lbs	Nm	ft-lbs	Nm	ft-lbs	Nm	ft-lbs	Nm	ft-lbs	Nm	ft-lbs	Nm	ft-lbs	Nm
8	5.4	7.41	7.2	9.88	14	19.1	18.8	25.5	20.1	27.3	26.9	36.5	23.6	32	31.4	42.6
10	10.8	14.7	14.4	19.6	27.9	37.8	37.2	50.5	39.9	54.1	53.2	72.2	46.7	63.3	62.3	84.4
12	18.9	25.6	25.1	34.1	48.6	66	64.9	88	69.7	94.5	92.2	125	81	110	108	147
14	30.1	40.8	40	54.3	77.4	105	103	140	110	150	147	200	129	175	172	234
16	46.9	63.6	62.5	84.8	125	170	166	226	173	235	230	313	202	274	269	365
18	64.5	87.5	86.2	117	171	233	229	311	238	323	317	430	278	377	371	503
20	91	124	121	165	243	330	325	441	337	458	450	610	394	535	525	713
22	124	169	166	225	331	450	442	600	458	622	612	830	536	727	715	970
24	157	214	210	285	420	570	562	762	583	791	778	1055	682	925	909	1233





## Scheduled Maintenance Procedures



### Observe and Obey:

- ☑ Maintenance inspections shall be completed by a person trained and qualified on the maintenance of this machine.
- ☑ Scheduled maintenance inspections shall be completed daily, quarterly, semi-annually, annually and every 2 years as specified of the *Maintenance inspection Report*. The frequency and extent of periodic examinations and tests may also depend on national regulations.

### **⚠ WARNING**

Failure to perform each procedure as presented and scheduled may cause death, serious injury or substantial damage.

- ☑ Immediately tag and remove from service a damaged or malfunctioning machine.
- ☑ Repair any machine damage or malfunction before operating the machine.
- ☑ Use only Genie approved replacement parts.
- ☑ Machines that have been out of service for a period longer than 3 months must complete the quarterly inspection.

### Machine Configuration:

- ☑ Unless otherwise specified, perform each procedure with the machine in the following configuration:
  - Machine parked on a firm, level surface
  - Key switch in the off position with the key removed
  - The red Emergency Stop button in the off position at both ground and platform controls
  - Wheels chocked
  - All external AC power supply disconnected from the machine
  - Boom in the stowed position
  - Turntable secured with the turntable rotation lock

---

# Scheduled Maintenance Procedures

## About This Section

This section contains detailed procedures for each scheduled maintenance inspection.

Each procedure includes a description, safety warnings and step-by-step instructions.

## Symbols Legend



Safety alert symbol—used to alert personnel to potential personal injury hazards. Obey all safety messages that follow this symbol to avoid possible injury or death.



Indicates a imminently hazardous situation which, if not avoided, will result in death or serious injury.



Indicates a potentially hazardous situation which, if not avoided, could result in death or serious injury.



Indicates a potentially hazardous situation which, if not avoided, may cause minor or moderate injury.



Indicates a potentially hazardous situation which, if not avoided, may result in property damage.

- ⊙ Indicates that a specific result is expected after performing a series of steps.
- ⊗ Indicates that an incorrect result has occurred after performing a series of steps.

# Scheduled Maintenance Procedures

## Maintenance Symbols Legend

Note: The following symbols have been used in this manual to help communicate the intent of the instructions. When one or more of the symbols appear at the beginning of a maintenance procedure, it conveys the meaning below.



Indicates that tools will be required to perform this procedure.



Indicates that new parts will be required to perform this procedure.



Indicates that dealer service will be required to perform this procedure.



Indicates that a cold motor or pump will be required to perform this procedure.

## Pre-delivery Preparation Report

The pre-delivery preparation report contains checklists for each type of scheduled inspection.

Make copies for each inspection. Store completed forms as required.

## Maintenance Schedule

The *Scheduled Maintenance Procedures* section and the *Maintenance Inspection Report* have been divided into subsections. Use the following chart to determine which group(s) of procedures are required to perform a scheduled inspection.

Inspection	Checklist
Daily or every 8 hours	A
Quarterly or every 250 hours	A + B
Semi-annually or every 500 hours	A + B + C
Annually or every 1000 hours	A + B + C + D
Two-year or every 2000 hours	A + B + C + D + E

## Maintenance Inspection Report

The maintenance inspection report contains checklists for each type of scheduled inspection.

Make copies of the *Maintenance Inspection Report* to use for each inspection. Maintain completed forms for a minimum of 4 years or in compliance with your employer, jobsite and governmental regulations and requirements.

# Pre-Delivery Preparation Report

## Fundamentals

It is the responsibility of the dealer to perform the Pre-delivery Preparation.

The Pre-delivery Preparation is performed prior to each delivery. The inspection is designed to discover if anything is apparently wrong with a machine before it is put into service.

A damaged or modified machine must never be used. If damage or any variation from factory delivered condition is discovered, the machine must be tagged and removed from service.

Repairs to the machine may only be made by a qualified service technician, according to the manufacturer's specifications.

Scheduled maintenance inspections shall be performed by qualified service technicians, according to the manufacturer's specifications and the requirements listed in the responsibilities manual.

## Instructions

Use the operator's manual on your machine.

The Pre-delivery Preparation consists of completing the Pre-operation Inspection, the Maintenance items and the Function Tests.

Use this form to record the results. Place a check in the appropriate box after each part is completed. Follow the instructions in the operator's manual.

If any inspection receives an N, remove the machine from service, repair and re-inspect it. After repair, place a check in the R box.

### Legend

- Y = yes, acceptable
- N = no, remove from service
- R = repaired

### Comments

Pre-delivery Preparation	Y	N	R
Pre-operation inspection completed			
Maintenance items completed			
Function tests completed			



**Terex South Dakota, Inc USA**  
 500 Oak Wood Road  
 PO Box 1150  
 Watertown, SD 57201-6150  
 (605) 882-4000

**Genie UK**  
 The Maltings, Wharf Road  
 Grantham, Lincolnshire  
 NG31-6BH England  
 (44) 1476-584333

Model

Serial number

Date

Machine owner

Inspected by (print)

Inspector signature

Inspector title

Inspector company

This page intentionally left blank.



# Maintenance Inspection Report

**Model**  

---

**Serial number**  

---

**Date**  

---

**Hour meter**  

---

**Machine owner**  

---

**Inspected by (print)**  

---

**Inspector signature**  

---

**Inspector title**  

---

**Inspector company**  

---

## Instructions

- Make copies of this report to use for each inspection.
- Select the appropriate checklist(s) for the type of inspection(s) to perform.

<input type="checkbox"/>	Daily or every 8 hours	A
<input type="checkbox"/>	Quarterly or every 250 hours	A + B
<input type="checkbox"/>	Semi-annually or every 500 hours	A + B + C
<input type="checkbox"/>	Annually or every 1000 hours	A + B + C + D
<input type="checkbox"/>	Two-year or every 2000 hours	A + B + C + D + E

- Place a check in the appropriate box after each inspection procedure is completed.
- Use the step-by-step procedures in this section to learn how to perform these inspections.
- If any inspection receives an "N," tag and remove the machine from service, repair and re-inspect it. After repair, place a check in the "R" box.

## Legend

Y = yes, acceptable  
 N = no, remove from service  
 R = repaired

Checklist A		Y	N	R
A-1	Inspect the manuals and decals			
A-2	Pre-operation inspection			
A-3	Function tests			

**Perform after 40 hours:**

A-4	30-day service			
-----	----------------	--	--	--

**Perform every 100 hours:**

A-5	Grease rotation bearing			
-----	-------------------------	--	--	--

**Perform after 150 hours:**

A-6	Drive hub oil			
-----	---------------	--	--	--

Checklist B		Y	N	R
B-1	Battery			
B-2	Electrical wiring			
B-3	Tires and wheels			
B-4	Brake configuration			
B-5	Drive hub oil			
B-6	Ground control override			
B-7	Platform leveling			
B-8	Drive brakes			
B-9	Drive speed - stowed			
B-10	Drive speed - raised			
B-11	Alarm package			
B-12	Turntable rotation stop			
B-13	Electrical contactors			
B-14	Hydraulic oil analysis			
B-15	Emergency power system			

Checklist C		Y	N	R
C-1	Grease platform overload (if equipped)			
C-2	Test platform overload (if equipped)			

Checklist D		Y	N	R
D-1	Boom wear pads			
D-2	Free-wheel configuration			
D-3	Turntable bearing bolts			
D-4	Drive hub oil			
D-5	Hydraulic filters			
D-6	Turntable bearing wear			

Checklist E		Y	N	R
E-1	Hydraulic oil			
E-2	Wheel bearings			

## Comments

---



---



---



## Checklist A Procedures

### A-1 Inspect the Manuals and Decals

Genie specifications require that this procedure be performed every 8 hours or daily, whichever comes first.

Maintaining the operator's and safety manuals in good condition is essential to safe machine operation. Manuals are included with each machine and should be stored in the container provided in the platform. An illegible or missing manual will not provide safety and operational information necessary for a safe operating condition.

In addition, maintaining all of the safety and instructional decals in good condition is mandatory for safe machine operation. Decals alert operators and personnel to the many possible hazards associated with using this machine. They also provide users with operation and maintenance information. An illegible decal will fail to alert personnel of a procedure or hazard and could result in unsafe operating conditions.

- 1 Check to make sure that the operator's and safety manuals are present and complete in the storage container on the platform.
- 2 Examine the pages of each manual to be sure that they are legible and in good condition.
  - ⦿ Result: The operator's manual is appropriate for the machine and all manuals are legible and in good condition.
  - ⊗ Result: The operator's manual is not appropriate for the machine or all manuals are not in good condition or is illegible. Remove the machine from service until the manual is replaced.

- 3 Open the operator's manual to the decals inspection section. Carefully and thoroughly inspect all decals on the machine for legibility and damage.
  - ⦿ Result: The machine is equipped with all required decals, and all decals are legible and in good condition.
  - ⊗ Result: The machine is not equipped with all required decals, or one or more decals are illegible or in poor condition. Remove the machine from service until the decals are replaced.
- 4 Always return the manuals to the storage container after use.

Note: Contact your authorized Genie distributor or Genie if replacement manuals or decals are needed.

---

## Checklist A Procedures

### A-2 Perform Pre-operation Inspection

Genie specifications require that this procedure be performed every 8 hours or daily, whichever comes first.

Completing a Pre-operation Inspection is essential to safe machine operation. The Pre-operation Inspection is a visual inspection performed by the operator prior to each work shift. The inspection is designed to discover if anything is apparently wrong with a machine before the operator performs the function tests. The Pre-operation Inspection also serves to determine if routine maintenance procedures are required.

Complete information to perform this procedure is available in the appropriate operator's manual. Refer to the Operator's Manual on your machine.

### A-3 Perform Function Tests

Genie specifications require that this procedure be performed every 8 hours or daily, whichever comes first.

Completing the function tests is essential to safe machine operation. Function tests are designed to discover any malfunctions before the machine is put into service. A malfunctioning machine must never be used. If malfunctions are discovered, the machine must be tagged and removed from service.

Complete information to perform this procedure is available in the appropriate operator's manual. Refer to the Operator's Manual on your machine.



## Checklist A Procedures

### A-4 Perform 30-Day Service



The 30-day maintenance procedure is a onetime procedure to be performed after the first 30 days or 40 hours of usage. After this interval, refer to the maintenance tables for continued scheduled maintenance.

- 1 Perform the following maintenance procedures:

#### All Models:

- A-5 Grease the Turntable Rotation Bearing and Rotate Gear
- B-3 Inspect the Tires, Wheels and Lug Nut Torque
- D-3 Check the Turntable Rotation Bearing Bolts
- D-5 Replace the Hydraulic Filters

### A-5 Grease the Turntable Rotation Bearing and Worm Drive Gear



Genie specifications require that this procedure be performed every 100 hours of operation. Perform this procedure more often if dusty conditions exist.

Frequent application of lubrication to the turntable bearing and rotate gear is essential to good machine performance and service life. Continued use of an improperly greased bearing and gear will result in component damage.

- 1 Locate the grease fitting on the tank side turntable cover bulkhead.
- 2 Pump grease into the turntable rotation bearing. Rotate the turntable in increments of 4 to 5 inches / 10 to 13 cm at a time and repeat this step until the entire bearing has been greased.
- 3 Locate the 2 grease fittings on top of the worm drive housing.

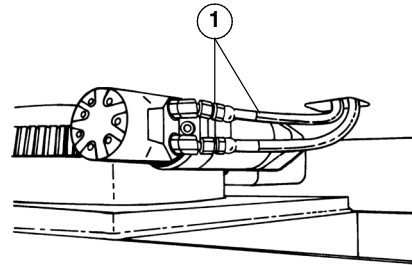

1 grease fittings

- 4 Pump grease into the gear until you see it coming out of the side of the gear housing.
- 5 Grease each tooth on the outside of the turntable rotation bearing.

---

#### Grease Specification

---

Chevron Ultra-duty grease, EP NLGI 2 (lithium based) or equivalent

---

## Checklist A Procedures

### A-6

### Replace the Drive Hub Oil



Drive hub specifications require that this one-time procedure be performed after the first 150 hours of usage. After this interval, refer to the maintenance checklist for continued scheduled maintenance.

Replacing the drive hub oil is essential for good machine performance and service life. Failure to replace the drive hub may cause the machine to perform poorly and continued use may cause component damage.

- 1 Select the drive hub to be serviced. Drive the machine until one of the two plugs is at the lowest point.
- 2 Remove the plugs and drain the oil into a suitable container.
- 3 Drive the machine until one of the two plugs is at the highest point.

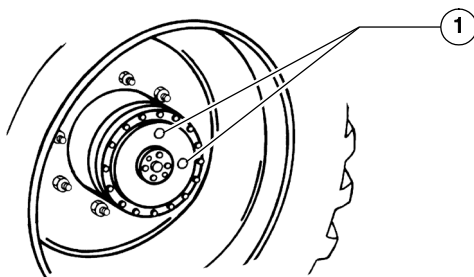

1 drive hub plugs

- 4 Fill the hub until the oil level is even with the bottom of the lowest plug hole. Refer to Specifications, *Machine Specifications*.
- 5 Install the plugs into the drive hub.
- 6 Repeat this procedure for each drive hub.

## Checklist B Procedures

### B-1 Inspect the Battery



Genie specifications require that this procedure be performed every 250 hours or quarterly, whichever comes first.

Proper battery condition is essential to good engine and machine performance and operational safety. Improper fluid levels or damaged cables and connections can result in engine and component damage and hazardous conditions.

**⚠ WARNING** Electrocution/burn hazard. Contact with electrically charged circuits could result in death or serious injury. Remove all rings, watches and other jewelry.

**⚠ WARNING** Bodily injury hazard. Batteries contain acid. Avoid spilling or contacting battery acid. Neutralize battery acid spills with baking soda and water.

Note: Fully charge the batteries and allow the batteries to rest 24 hours before performing this procedure to allow the battery cells to equalize.

- 1 Open the side covers.
- 2 Be sure that the battery cable connections are free of corrosion.

Note: Adding terminal protectors and a corrosion preventative sealant will help eliminate corrosion on the battery terminals and cables.

- 3 Be sure that the battery retainers and cable connections are tight.
- 4 Be sure that the battery separator wire connections are tight (if equipped).
- 5 Put on protective clothing and eye wear.
- 6 Remove the battery vent caps and check the specific gravity of each battery cell with a hydrometer. Note the results.
- 7 Check the ambient air temperature and adjust the specific gravity reading for each cell as follows:
  - Add 0.004 to the reading of each cell for every 10° / 5.5° C above 80° F / 26.7° C.
  - Subtract 0.004 from the reading of each cell for every 10° / 5.5° C below 80° F / 26.7° C.
- ⊙ Result: All battery cells display an adjusted specific gravity of 1.277 or higher. The battery is fully charged. Proceed to step 11.
- ⊗ Result: One or more battery cells display a specific gravity of 1.217 or below. Proceed to step 8.
- 8 Perform an equalizing charge OR fully charge the battery(s) and allow the battery(s) to rest at least 6 hours.
- 9 Remove the battery vent caps and check the specific gravity of each battery cell with a hydrometer. Note the results.

## Checklist B Procedures

- 10 Check the ambient air temperature and adjust the specific gravity reading for each cell as follows:
- Add 0.004 to the reading of each cell for every 10° / 5.5° C above 80° F / 26.7° C.
  - Subtract 0.004 from the reading of each cell for every 10° / 5.5° C below 80° F / 26.7° C.
- ⊙ Result: All battery cells display a specific gravity of 1.277 or greater. The battery is fully charged. Proceed to step 11.
- ⊗ Result: One or more battery cells display a specific gravity from 1.218 to 1.269. The battery is still usable, but at a lower performance. The battery will need to be recharged more often. Proceed to step 11.
- ⊗ Result: One or more battery cells display a specific gravity from 1.217 to 1.173. The battery is approaching the end of its life. Proceed to step 11.
- ⊗ Result: The difference in specific gravity readings between cells is greater than 0.1 OR the specific gravity of one or more cells is less than 1.177. Replace the battery.
- 11 Check the battery acid level. If needed, replenish with distilled water to 1/8 inch / 3 mm below the bottom of the battery fill tube. Do not overfill.
- 12 Install the vent caps and neutralize any electrolyte that may have spilled.

### B-2

## Inspect the Electrical Wiring



Genie specifications require that this procedure be performed every 250 hours or quarterly, whichever comes first.

Maintaining electrical wiring in good condition is essential to safe operation and good machine performance. Failure to find and replace burnt, chafed, corroded or pinched wires could result in unsafe operating conditions and may cause component damage.

#### **⚠ WARNING**

Electrocution/burn hazard. Contact with electrically charged circuits could result in death or serious injury. Remove all rings, watches and other jewelry.

- 1 Remove the drive chassis cover from the non-steer end of the machine.
- 2 Inspect the following areas for burnt, chafed, corroded and loose wires:
  - Electrical power panel
  - Electrical relay panel
  - Ground control panel
  - Function manifold wiring

## Checklist B Procedures

- 3 Turn the key switch to ground controls and pull out the red Emergency Stop button to the on position at both the ground and platform controls.
- 4 Raise the secondary boom until the mid-pivot is approximately 10 feet / 3 m off the ground.
- 5 Inspect the turntable center area for burnt, chafed and pinched cables.
- 6 Lower the boom to the stowed position and turn the machine off.
- 7 Inspect the following areas for burnt, chafed, corroded, pinched and loose wires:
  - Cable track on the primary boom
  - Primary boom to platform cable harness
  - Inside of the platform control box
- 8 Inspect for a liberal coating of dielectric grease at the following location:
  - All wire harness connectors to the platform control box
  - All wire harness connectors located under the ground control side turntable cover
  - Harness connector to the drive motor controller located in the non-steer end of the drive chassis

### B-3

## Inspect the Tires, Wheels and Lug Nut Torque



Genie specifications require that this procedure be performed every 250 hours or quarterly, whichever comes first.

Maintaining the tires and wheels, including proper wheel fastener torque, is essential to safe operation and good performance. Tire and/or wheel failure could result in a machine tip-over. Component damage may also result if problems are not discovered and repaired in a timely fashion.

#### **▲ WARNING**

Bodily injury hazard. An over-inflated tire can explode and could cause death or serious injury.

#### **▲ WARNING**

Tip-over hazard. Do not use temporary flat tire repair products.

Note: The tires on some machines are foam-filled and do not need air added to them.

- 1 Check all tire treads and sidewalls for cuts, cracks, punctures and unusual wear.
- 2 Check each wheel for damage, bends and cracked welds.
- 3 Check each lug nut for proper torque. Refer to Specifications, *Machine Specifications*.
- 4 Check the pressure in each air-filled tire.

## Checklist B Procedures

### B-4 Confirm the Proper Brake Configuration



Genie specifications require that this procedure be performed every 250 hours or quarterly, whichever comes first.

Proper brake configuration is essential to safe operation and good machine performance. Hydrostatic brakes and hydraulically-released, spring-applied individual wheel brakes can appear to operate normally when they are actually not fully operational.

- 1 Check each drive hub disconnect cap to be sure it is in the engaged position.

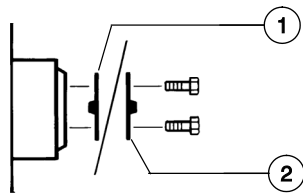

- 1 brake disengaged position
- 2 brake engaged position

### B-5 Check the Drive Hub Oil Level and Fastener Torque



Genie specifications require that this procedure be performed every 250 hours or quarterly, whichever comes first.

Failure to maintain proper drive hub oil levels may cause the machine to perform poorly and continued use may cause component damage.

- 1 Drive the machine to rotate the hub until the plugs are located one on top and the other at 90 degrees.

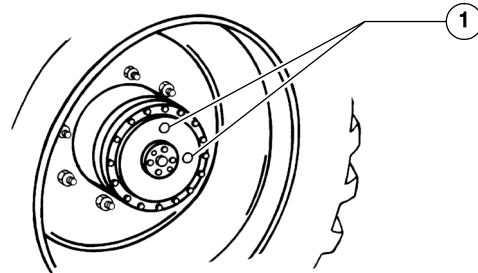

- 1 drive hub plugs

- 2 Remove the plug located at 90 degrees and check the oil level.
  - ⦿ Result: The oil level should be even with the bottom of the plug hole.

---

## Checklist B Procedures

- 3 If necessary, remove the top plug and add oil until the oil level is even with the bottom of the side plug hole.
- 4 Install the plug(s) into the drive hub.
- 5 Check the torque of the drive hub mounting bolts. Refer to Specifications, *Machine Specifications*.
- 6 Repeat this procedure for each drive hub.

### B-6

#### Test the Ground Control Override

Genie specifications require that this procedure be performed every 250 hours or quarterly, whichever comes first.

A properly functioning ground control override is essential to safe machine operation. The ground control override function is intended to allow ground personnel to operate the machine from the ground controls whether or not the Emergency Stop button on the platform controls is in the on or off position. This function is particularly useful if the operator at the platform controls cannot return the boom to the stowed position.

- 1 Push in the red Emergency Stop button at the platform controls to the off position.
  - 2 Turn the key switch to ground controls and pull out the red Emergency Stop button to the on position.
  - 3 Operate each boom function through a partial cycle at the ground controls.
- ⊙ Result: All boom functions should operate.

## Checklist B Procedures

### B-7

#### Test the Platform Self-leveling



Note: Genie specifications require that this procedure be performed every 250 hours or quarterly, whichever comes first.

Automatic platform self-leveling throughout the full cycle of boom raising and lowering is essential for safe machine operation. The platform is maintained level by the platform leveling slave cylinder which is controlled by the platform leveling master cylinder located at the base of the primary boom. A platform self-leveling failure creates an unsafe working condition for platform and ground personnel.

- 1 Turn the key switch to ground controls and pull out the red Emergency Stop button to the on position at both the ground and platform controls.
  - 2 Lower the boom to the stowed position.
  - 3 Adjust the platform to a level position using the platform leveling toggle switch.
  - 4 Raise and lower the primary boom through a full cycle.
- ⊙ Result: The platform should remain level at all times to within  $\pm 5$  degrees.

### B-8

#### Test the Drive Brakes



Genie specifications require that this procedure be performed every 250 hours or quarterly, whichever comes first.

Proper brake action is essential to safe machine operation. The drive brake function should operate smoothly, free of hesitation, jerking and unusual noise. Hydraulically-released individual wheel brakes can appear to operate normally when they are actually not fully operational.

#### **⚠ WARNING**

Collision hazard. Be sure that the machine is not in free-wheel or partial free-wheel configuration. Refer to maintenance procedure, *Confirm the Proper Brake Configuration*.

Note: Select a test area that is firm, level and free of obstructions.

- 1 Mark a test line on the ground for reference.
- 2 Lower the boom to the stowed position.
- 3 Turn the key switch to platform controls.
- 4 Choose a point on the machine (i.e., contact patch of a tire) as a visual reference for use when crossing the test line.
- 5 Bring the machine to top drive speed before reaching the test line. Release the drive joystick when your reference point on the machine crosses the test line.
- 6 Measure the distance between the test line and your machine reference point. Refer to Specifications, *Performance Specifications*.

Note: The brakes must be able to hold the machine on any slope it is able to climb.



## Checklist B Procedures

### B-9 Test the Drive Speed – Stowed Position



Genie specifications require that this procedure be performed every 250 hours or quarterly, whichever comes first.

Proper drive functions are essential to safe machine operation. The drive function should respond quickly and smoothly to operator control. Drive performance should also be free of hesitation, jerking and unusual noise over the entire proportionally controlled speed range.

Note: Select a test area that is firm, level and free of obstructions.

- 1 Create start and finish lines by marking two lines on the ground 40 feet / 12.2 m apart.
- 2 Turn the key switch to platform control and pull out the red Emergency Stop button to the on position at both the ground and platform controls.
- 3 Lower the boom to the stowed position.
- 4 Choose a point on the machine; i.e., contact patch of a tire, as a visual reference for use when crossing the start and finish lines.
- 5 Bring the machine to top drive speed before reaching the start line. Begin timing when your reference point on the machine crosses the start line.
- 6 Continue at full speed and note the time when the machine reference point crosses the finish line. Refer to Specifications, *Performance Specifications*.

## Checklist B Procedures

### B-10

#### Test the Drive Speed – Raised or Extended Position



Genie specifications require that this procedure be performed every 250 hours or quarterly, whichever comes first.

Proper drive functions are essential to safe machine operation. The drive function should respond quickly and smoothly to operator control. Drive performance should also be free of hesitation, jerking and unusual noise over the entire proportionally controlled speed range.

Note: Select a test area that is firm, level and free of obstructions.

- 1 Create start and finish lines by marking two lines on the ground 40 feet / 12.2 m apart.
- 2 Choose a point on the machine; i.e., contact patch of a tire, as a visual reference for use when crossing the start and finish lines.
- 3 Bring the machine to top drive speed before reaching the start line. Begin timing when your reference point on the machine crosses the start line.
- 4 Continue at full speed and note the time when the machine reference point crosses the finish line. Refer to Specifications, *Performance Specifications*.
- 5 Lower the boom to the stowed position and extend the boom 1 foot / 30 cm.
- 6 Choose a point on the machine; i.e., contact patch of a tire, as a visual reference for use when crossing the start and finish lines.
- 7 Bring the machine to top drive speed before reaching the start line. Begin timing when your reference point on the machine crosses the start line.
- 8 Continue at full speed and note the time when the machine reference point crosses the finish line. Refer to Specifications, *Performance Specifications*.

## Checklist B Procedures

### B-11 Test the Alarm Package (if equipped)

Genie specifications require that this procedure be performed every 250 hours or quarterly, whichever comes first.

The alarm package includes:

- Travel alarm
- Descent alarm
- Flashing beacon

Alarms and a beacon are installed to alert operators and ground personnel of machine proximity and motion. The alarm package is installed on the turntable covers.

- 1 At the ground controls, pull out the red Emergency Stop button to the on position and turn the key switch to ground control.
  - ⊙ Result: The flashing beacon should be on and flashing.
- 2 Move the primary boom switch to the down position, hold for a moment and then release it. Move the secondary boom switch to the down position, hold for a moment and then release it. Move the jib boom switch to the down position, hold for a moment and then release it.
  - ⊙ Result: The descent alarm should sound when each switch is held down.
- 3 Turn the key switch to platform control.
- 4 At the platform controls pull out the red Emergency Stop button to the on position.
  - ⊙ Result: The flashing beacon should be on and flashing.
- 5 Press down the foot switch. Move the primary boom switch to the down position, hold for a moment and then release it. Move the secondary boom switch to the down position, hold for a moment and then release it. Move the jib boom switch to the down position, hold for a moment and then release it.
  - ⊙ Result: The descent alarm should sound when each control switch is held down.
- 6 Press down the foot switch. Move the drive control handle off center, hold for a moment and then release it. Move the drive control handle off center in the opposite direction, hold for a moment and then release it.
  - ⊙ Result: The travel alarm should sound when the drive control handle is moved off center in either direction.

## Checklist B Procedures

### B-12

#### Test the Turntable Rotation Stop

Note: Genie specifications require that this procedure be performed every 250 hours or quarterly, whichever comes first.

The turntable is capable of rotating the boom 359 degrees and is stopped midpoint between the steer wheels by the rotation stop. Detecting a rotation stop malfunction is essential to safe operation and good machine performance. If the turntable rotates past the rotation stop, component damage may result.

- 1 Turn the key switch to platform controls and pull out the red Emergency Stop buttons to the on position at both ground and platform controls.
- 2 Rotate the turntable to the left as far as it will go.
  - ⊙ Result: Movement should stop when the primary boom reaches midpoint between the steer tires.
- 3 Rotate the turntable to the right as far as it will go.
  - ⊙ Result: Movement should stop when the primary boom reaches midpoint between the steer tires.

### B-13

#### Check the Electrical Contactors



Note: Genie specifications require that this procedure be performed every 250 hours or quarterly, whichever comes first.

Maintaining the electrical contactors in good condition is essential to safe machine operation. Failure to locate a worn or damaged contactor could result in an unsafe working condition and component damage.

- 1 Remove the drive chassis cover from the non-steer end of the machine and locate the electrical contactors mounted on the electrical component mounting panel.
- 2 Visually inspect the contact points of each contactor for the following items:
  - Excessive burns
  - Excessive arcs
  - Excessive pitting

#### **⚠ WARNING**

Electrocution/burn hazard. Contact with electrically charged circuits could result in death or serious injury. Remove all rings, watches and other jewelry.

Note: Replace the contactors if any damage is found.

## Checklist B Procedures

### B-14 Perform Hydraulic Oil Analysis



Genie specifications require that this procedure be performed every 250 hours or quarterly, whichever comes first.

Replacement or testing of the hydraulic oil is essential for good machine performance and service life. Dirty oil and a clogged suction strainer may cause the machine to perform poorly and continued use may cause component damage. Extremely dirty conditions may require oil changes to be performed more often. For hydraulic oil specifications, refer to Specifications, *Hydraulic Specifications*.

Note: Before replacing the hydraulic oil, the oil may be tested by an oil distributor for specific levels of contamination to verify that changing the oil is necessary. If the hydraulic oil is not replaced at the two year inspection, test the oil quarterly. Replace the oil when it fails the test. Refer to Maintenance Procedure, *Test or Replace the Hydraulic Oil*.

### B-15 Test the Emergency Power System



Genie specifications require that this procedure be performed every 250 hours or quarterly, whichever comes first.

Testing the emergency power system regularly is essential to safe machine operation if the primary power source fails.

- 1 Turn the key switch to ground control and pull out the red Emergency Stop button to the on position at both the ground and platform controls.
- 2 At the ground controls, break the security tie and lift the emergency power switch cover (if equipped).
- 3 Simultaneously hold the emergency power switch on and activate each boom function toggle switch.

Note: To conserve battery power, test each function through a partial cycle.

- ⦿ Result: All boom functions operate.
- 4 Close the emergency power switch cover and secure the cover with a security tie (if equipped).

---

## Checklist B Procedures

- 5 Turn the key switch to platform controls.
- 6 At the platform controls, break the security tie and lift the emergency power switch cover (if equipped).
- 7 Press down on the foot switch and simultaneously hold the emergency power switch on and activate each boom function.

Note: To conserve battery power, test each function through a partial cycle.

- ⊙ Result: All boom functions operate.
- 8 Close the emergency power switch cover and secure the cover with a security tie (if equipped).

## Checklist C Procedures

### C-1 Grease the Platform Overload Mechanism (if equipped)



Genie specifications require that this procedure be performed every 500 hours or six months, whichever comes first.

Perform this procedure more often if dusty conditions exist.

Application of lubrication to the platform overload mechanism is essential to safe machine operation. Continued use of an improperly greased platform overload mechanism could result in the system not sensing an overloaded platform condition and will result in component damage.

- 1 Locate the grease fittings on each pivot pin of the platform overload assembly.
- 2 Thoroughly pump grease into each grease fitting.

---

#### Grease Specification

---

Chevron Ultra-duty grease, EP NLGI 1 (lithium based) or equivalent

---

### C-2 Test the Platform Overload System (if equipped)



Genie specifications require that this procedure be performed every 500 hours or six months, whichever comes first OR when the machine fails to lift the maximum rated load.

Testing the platform overload system regularly is essential to safe machine operation. Continued use of an improperly operating platform overload system could result in the system not sensing an overloaded platform condition. Machine stability could be compromised resulting in the machine tipping over.

Note: Perform this procedure with the boom fully retracted and in the stowed position and with the machine on a firm, level surface.

- 1 Remove all weight, tools and equipment from the platform.

Note: Failure to remove all weight, tools and accessories from the platform will result in an inaccurate test.

- 2 Turn the key switch to platform controls and pull out the red Emergency Stop button to the on position at both the ground and platform controls. Level the platform.
- 3 Determine the maximum platform capacity. Refer to the machine serial plate.

## Checklist C Procedures

- 4 Using a suitable lifting device, place a test weight equal to that of the available capacity in one of the locations shown. Refer to Illustration 1.
  - ⦿ Result: The platform overload indicator lights should be off at both the ground and platform controls and the alarm should not sound.

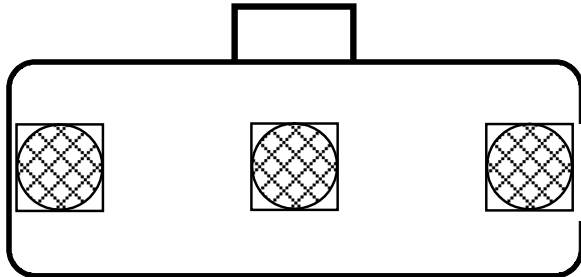

illustration 1

- 5 Carefully move the test weights to each remaining location on the platform. Refer to Illustration 1.
  - ⦿ Result: The platform overload indicator lights should be off at both the ground and platform controls and the alarm should not sound.
- 6 Add additional weight to the platform that is equal to, but does not exceed 15% of the maximum rated load. Secure the additional weight. Refer to the machine serial plate.
  - ⦿ Result: The platform overload indicator lights should be flashing at both the ground and platform controls and the alarm should sound.

Note: There may be a 2 second delay before the overload indicator lights flash and the alarm sounds.

- 7 Carefully move the test weights to each remaining location on the platform. Refer to Illustration 1.
  - ⦿ Result: The platform overload indicator lights should be flashing at both the ground and platform controls and the alarm should sound.

Note: There may be a 2 second delay before the overload indicator lights flash and the alarm sounds.

- 8 Turn the key switch to ground control.
- 9 Using auxiliary power, test all machine functions from the ground controls.
  - ⦿ Result: All ground control functions should not operate.
- 10 Using a suitable lifting device, lift the additional test weight from the platform.
  - ⦿ Result: The platform overload indicator lights should turn off at both the ground and platform controls and the alarm should not sound.

Note: There may be a 2 second delay before the overload indicator lights and alarm turn off.

- 11 Test all machine functions from the ground controls.
  - ⦿ Result: All ground control functions should operate normally.
- 12 Using a suitable lifting device, remove all test weights from the platform.



## Checklist D Procedures

### D-1

#### Check the Boom Wear Pads



Genie specifications require that this procedure be performed every 1000 hours or annually, whichever comes first.

Maintaining the boom wear pads in good condition is essential to safe machine operation. Wear pads are placed on boom tube surfaces to provide a low friction, replaceable wear pad between moving parts. Improperly shimmed wear pads or continued use of extremely worn wear pads may result in component damage and unsafe operating conditions.

- 1 Measure each wear pad. Replace the wear pad once it reaches the minimum allowable thickness. If the wear pad is still within specification, shim as necessary to obtain minimum clearance with zero binding.
- 2 Extend and retract the boom through the entire range of motion to check for tight spots that may cause binding or scraping of the boom.

Note: Always maintain squareness between the outer and inner boom tubes.

---

#### Models without rotating jib boom:

Primary boom wear pad specifications	Minimum
Top and side wear pads (extension end of boom)	5/8 inch 15.9 mm
Bottom wear pads (extension end of boom)	5/8 inch 15.9 mm
Bottom and side wear pads (pivot end of boom)	5/8 inch 15.9 mm
Top wear pads (pivot end of boom)	3/8 inch 9.5 mm

---

#### Models with rotating jib boom:

Primary boom wear pad specifications	Minimum
All wear pads	3/8 inch 9.5 mm

## Checklist D Procedures

### D-2

### Check the Free-wheel Configuration



Genie specifications require that this procedure be performed every 1000 hours or annually, whichever comes first.

Proper use of the free-wheel configuration is essential to safe machine operation. The free-wheel configuration is used primarily for towing. A machine configured to free-wheel without operator knowledge may cause death or serious injury and property damage.

**⚠ WARNING** Collision hazard. Select a work site that is firm and level.

**NOTICE** Component damage hazard. If the machine must be towed, do not exceed 2 mph / 3.2 km/h.

- 1 Chock the steer wheels to prevent the machine from rolling.
- 2 Center a lifting jack of ample capacity (20,000 lbs / 10,000 kg) under the drive chassis between the non-steer tires.
- 3 Lift the wheels off the ground and then place jack stands under the drive chassis for support.

- 4 Disengage the drive hubs by turning over the drive hub disconnect caps on each non-steer wheel hub.

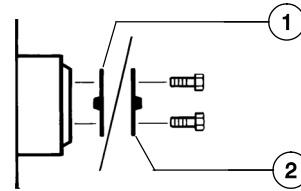

- 1 brake disengaged position
- 2 brake engaged position

- 5 Manually rotate each non-steer wheel.
  - ⦿ Result: Each non-steer wheel should rotate with minimum effort.
- 6 Re-engage the drive hubs by turning over the hub disconnect caps. Rotate each wheel to check for engagement. Raise the machine, remove the jack stands and lower the machine.

**⚠ WARNING** Collision hazard. Failure to re-engage the drive hubs could result in death or serious injury and property damage.

## Checklist D Procedures

### D-3 Check the Turntable Rotation Bearing Bolts



Genie specifications require that this procedure be performed every 1000 hours or annually, whichever comes first.

Maintaining proper torque on the turntable bearing bolts is essential to safe machine operation. Improper bolt torque could result in an unsafe operating condition and component damage

- 1 Raise the secondary boom and place a safety check on the lift cylinder rods. Carefully lower the boom onto the lift cylinder safety check.

**⚠ WARNING** Crushing hazard. Keep hands away from the cylinder and all moving parts when lowering the boom.

Note: The lift cylinder safety check is available through Genie After Market Support.

- 2 Confirm that each turntable mounting bolt is torqued in sequence to specification. Refer to Specifications, *Machine Torque Specifications*.

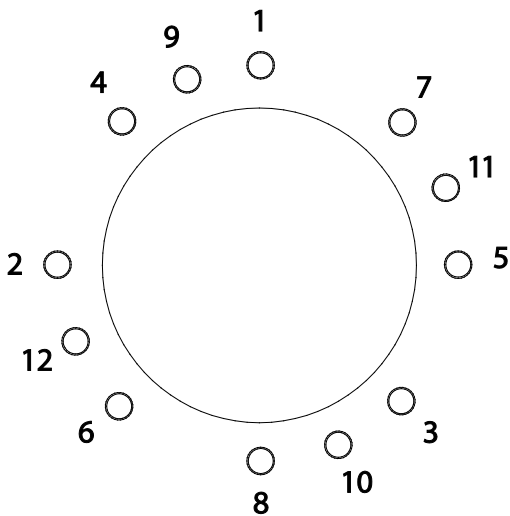

Bolt torque sequence

- 3 Raise the secondary boom and remove the safety chocks.
- 4 Lower the boom to the stowed position.
- 5 Open the latch on the battery packs and swing them out to expose the turntable bearing bolt access hole.
- 6 Torque the lower bearing mounting bolts under the drive chassis in sequence to specification. Refer to Specifications, *Machine Torque Specifications*.

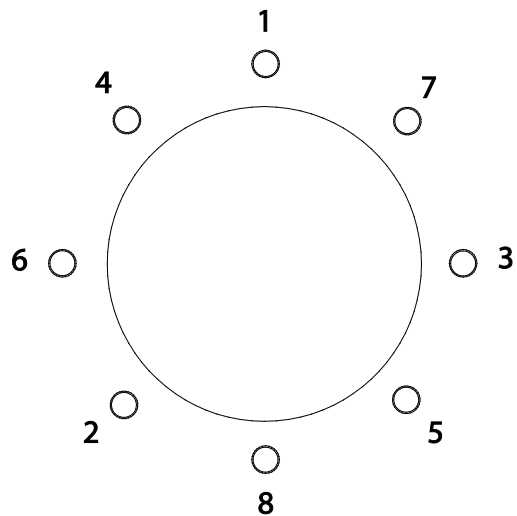

Bolt torque sequence

## Checklist D Procedures

### D-4

#### Replace the Drive Hub Oil



Genie specifications require that this procedure be performed every 1000 hours or annually, whichever comes first.

Replacing the drive hub oil is essential for good machine performance and service life. Failure to replace the drive hub oil at yearly intervals may cause the machine to perform poorly and continued use may result in component damage.

- 1 Select the drive hub to be serviced. Drive the machine until one of the two plugs is at the lowest point.
- 2 Remove the plugs and drain the oil into a suitable container.
- 3 Drive the machine until one of the two plugs is at the highest point.

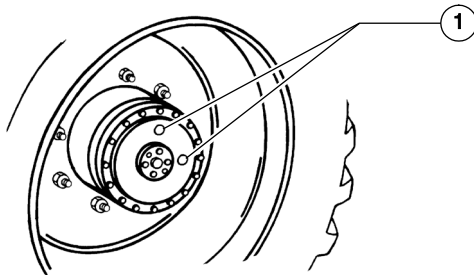

1 drive hub plugs

- 4 Fill the hub until the oil level is even with the bottom of the lowest plug hole. Refer to Specifications, *Machine Specifications*.
- 5 Repeat this procedure for each drive hub.

### D-5

#### Replace the Hydraulic Tank Return Filter Element



Note: Genie specifications require that this procedure be performed every 1000 hours or annually, whichever comes first. Perform this procedure more often if dusty conditions exist.

Replacement of the hydraulic return filter element is essential for good machine performance and service life. A dirty or clogged filter element may cause the machine to perform poorly and continued use may cause component damage. Extremely dirty conditions may require that the filter element be replaced more often.

#### **CAUTION**

Bodily injury hazard. Beware of hot oil. Contact with hot oil may cause severe burns.

- 1 Locate the hydraulic return filter housing on top of the hydraulic tank.
- 2 Clean the area around the oil filter housing cap located on top of the reservoir.
- 3 Remove the cap from the housing.
- 4 Lift the handle on the filter element and rotate the element counterclockwise to release the element from the housing.
- 5 Remove the filter element from the filter housing.

## Checklist D Procedures

- 6 Install the new oil filter element into the filter housing.
- 7 Push the filter element down to be sure the o-ring on the element is fully seated into the housing.
- 8 Rotate the filter element clockwise to lock it in place.
- 9 Install the filter housing cap.
- 10 Clean up any oil that may have spilled during the replacement procedure.
- 11 Use a permanent ink marker to write the date and number of hours from the hour meter on the oil filter housing.
- 12 Turn the key switch to ground controls and pull out the red Emergency Stop button to the on position.
- 13 Move and hold the function enable toggle switch to either side and move and hold the primary boom toggle switch in the up direction.
- 14 Inspect the filter housing and related components to be sure that there are no leaks.

### D-6

#### Inspect for Turntable Bearing Wear



Genie specifications require that this procedure be performed every 1000 hours or annually, whichever comes first.

Periodic inspection of turntable bearing wear is essential to safe machine operation, good machine performance and service life. Continued use of a worn turntable bearing could create an unsafe operating condition, resulting in death or serious injury and component damage.

Note: Perform this procedure with the machine on a firm, level surface with the boom in the stowed position.

- 1 Grease the turntable bearing. Refer to Maintenance Procedure, *Grease the Turntable Bearing and Rotate Gear*.
- 2 Torque the turntable bearing bolts to specification. Refer to Maintenance Procedure, *Check the Turntable Rotation Bearing Bolts*.
- 3 Raise the primary and secondary booms to full height using the ground controls. Do not extend the primary boom.

## Checklist D Procedures

- 4 Place a dial indicator between the drive chassis and the turntable at a point that is directly under, or inline with, the boom and no more than 1 inch / 2.5 cm from the bearing.

Note: To obtain an accurate measurement, place the dial indicator no more than 1 inch / 2.5 cm from the turntable rotation bearing.

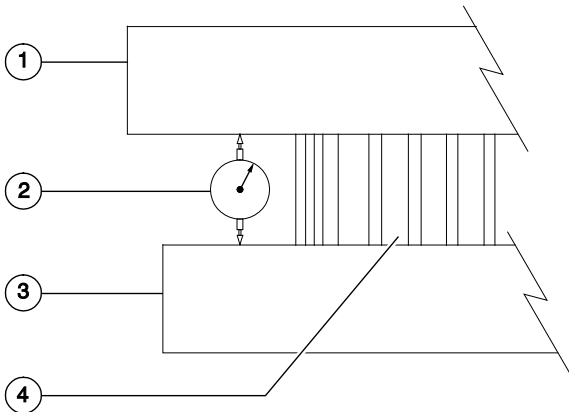

- 1 turntable
- 2 dial indicator
- 3 drive chassis
- 4 turntable rotation bearing

- 5 Adjust the dial indicator needle to the "zero" position.
- 6 Lower the secondary boom to the stowed position and lower the primary boom to a horizontal position. Fully extend the primary boom.

- 7 Note the reading on the dial indicator.
- ⊙ Result: The measurement is less than 0.055 inch / 1.4 mm. The bearing is good.
  - ⊗ Result: The measurement is more than 0.055 inch / 1.4 mm. The bearing is worn and needs to be replaced.
- 8 Fully retract the primary boom. Raise the primary and secondary booms to full height. Visually inspect the dial indicator to be sure the needle returns to the "zero" position.
- 9 Remove the dial indicator and rotate the turntable 90°.
- 10 Repeat steps 4 through 9 until the rotation bearing has been checked in at least four equally spaced areas 90° apart.
- 11 Lower the primary and secondary booms to the stowed position and turn the machine off.
- 12 Remove the dial indicator from the machine.

## Checklist E Procedures

### E-1 Test or Replace the Hydraulic Oil



Genie specifications require that this procedure be performed every 2000 hours or every two years, whichever comes first.

Perform this procedure more often if dusty conditions exist.

Replacement or testing of the hydraulic oil is essential for good machine performance and service life. Dirty oil and a clogged suction strainer or hydraulic filters may cause the machine to perform poorly and continued use may cause component damage. Extremely dirty conditions may require oil changes to be performed more frequently.

**Note:** Before replacing the hydraulic oil, the oil may be tested by an oil distributor for specific levels of contamination to verify that changing the oil is necessary. If the hydraulic oil is not replaced at the two year inspection, test the oil quarterly. Replace the oil when it fails the test.

**Note:** When removing a hose assembly or fitting, the O-ring (if equipped) on the fitting and/or hose end must be replaced. All connections must be torqued to specification during installation. Refer to Specifications, *Hydraulic Hose and Fitting Torque Specifications*.

**Note:** Perform this procedure with the boom in the stowed position.

- 1 Close the two hydraulic tank shut-off valves at the hydraulic tank.

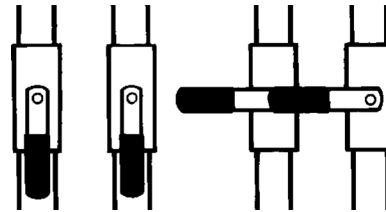

open

closed

#### NOTICE

Component damage hazard. The engine must not be started with the hydraulic tank shut-off valves in the closed position or component damage will occur. If the tank valves are closed, remove the key from the key switch and tag the machine to inform personnel of the condition.

- 2 Place a suitable container under the hydraulic tank. Refer to Section 2, Specifications.
- 3 Tag, disconnect and plug the hydraulic hose from the hydraulic tank shutoff valve.

#### WARNING

Bodily injury hazard. Spraying hydraulic oil can penetrate and burn skin. Loosen hydraulic connections very slowly to allow the oil pressure to dissipate gradually. Do not allow oil to squirt or spray.

## Checklist E Procedures

- 4 Open the valve on the hydraulic tank and completely drain the oil into a suitable container.

**CAUTION** Bodily injury hazard. Beware of hot oil. Contact with hot oil may cause severe burns.

- 5 Tag, disconnect and plug the hydraulic hoses from the hydraulic tank return filter housing. Cap the fittings on the filter housing.

**WARNING** Bodily injury hazard. Spraying hydraulic oil can penetrate and burn skin. Loosen hydraulic connections very slowly to allow the oil pressure to dissipate gradually. Do not allow oil to squirt or spray.

**CAUTION** Bodily injury hazard. Beware of hot oil. Contact with hot oil may cause severe burns.

- 6 Remove the hydraulic tank mounting fasteners. Remove the hydraulic tank from the machine.
- 7 Remove the tank lid retaining fasteners and remove the lid and return filter assembly from the tank.
- 8 Remove the suction strainer from the hydraulic tank and clean it using a mild solvent.

- 9 Rinse out the inside of the tank with a mild solvent.

- 10 Install the suction strainer into the tank.

- 11 Install the lid and return filter assembly onto the hydraulic tank.

- 12 Install the hydraulic tank on the machine. Install the hydraulic tank mounting fasteners and torque them to 8 ft-lbs / 10.8 Nm.

**NOTICE** Component damage hazard. The hydraulic tank is plastic and may become damaged if the tank mounting fasteners are over tightened.

- 13 Install the hydraulic hoses.

- 14 Fill the tank with hydraulic oil until the fluid is within the full and add marks on the hydraulic tank. Do not overfill. Refer to Specifications, *Machine Specifications*.

- 15 Clean up any oil that may have spilled. Properly discard of used oil.

- 16 Open the hydraulic tank shutoff valve.

**NOTICE** Component damage hazard. Be sure to open the hydraulic tank shutoff valve after installing the hydraulic tank.



## Checklist E Procedures

### E-2 Grease the Steer Axle Wheel Bearings, 2WD Models



Genie specifications require that this procedure be performed every 2000 hours or every two years, whichever comes first.

Perform this procedure more often if dusty conditions exist.

Maintaining the steer axle wheel bearings is essential for safe machine operation and service life. Operating the machine with loose or worn wheel bearings may cause an unsafe operating condition and continued use may result in component damage. Extremely wet or dirty conditions or regular steam cleaning and pressure washing of the machine may require that this procedure be performed more often.

- 1 Loosen the wheel lug nuts. Do not remove them.
- 2 Block the non-steer wheels, then center a lifting jack under the steer axle.
- 3 Raise the machine 6 inches / 15 cm and place blocks under the drive chassis for support.
- 4 Remove the lug nuts. Remove the tire and wheel assembly.
- 5 Check for wheel bearing wear by attempting to move the wheel hub side to side, then up and down.
  - ⊙ Result: There should be no side to side or up and down movement.

**Skip to step 10 if there is no movement.**

- 6 Remove the dust cap from the hub. Remove the cotter pin from the castle nut.
- 7 Tighten the castle nut to 35 ft-lbs / 47 Nm to seat the bearings.
- 8 Loosen the castle nut and re-tighten to 8 ft-lbs / 11 Nm.
- 9 Check for wheel bearing wear by attempting to move the wheel hub side to side, then up and down.
  - ⊙ Result: If there is no side to side or up and down movement, continue with step 11 and grease the wheel bearings.
  - ⊗ Result: If there is side to side or up and down movement, continue to step 11 and replace the wheel bearings with new ones.

Note: When replacing a wheel bearing, both the inner and outer bearings, including the pressed-in races, must be replaced.

- 10 Remove the dust cap from the hub. Remove the cotter pin from the castle nut.
- 11 Remove the castle nut.
- 12 Pull the hub off of the spindle. The washer and outer bearing should fall loose from the hub.
- 13 Place the hub on a flat surface and gently pry the bearing seal out of the hub. Remove the rear bearing.
- 14 Pack both bearings with clean, fresh grease.

---

## Checklist E Procedures

- 15 Place the large inner bearing into the rear of the hub.
- 16 Install a new bearing grease seal into the hub by pressing it evenly into the hub until it is flush.
- 17 Slide the hub onto the yoke spindle.

**NOTICE** Component damage hazard. Do not apply excessive force or damage to the lip of the seal may occur.

- 18 Place the outer bearing into the hub.
- 19 Install the washer and castle nut.
- 20 Tighten the slotted nut to 35 ft-lbs / 47 Nm to seat the bearings.
- 21 Loosen the castle nut and re-tighten to 8 ft-lbs / 11 Nm.
- 22 Install a new cotter pin. Bend the cotter pin to lock it in.

Note: Always use a new cotter pin when installing a castle nut.

- 23 Install the dust cap, then the tire and wheel assembly. Torque the wheel lug nuts to specification. Refer to Specifications, *Machine Specifications*.

## Repair Procedures



### Observe and Obey:

- Repair procedures shall be completed by a person trained and qualified on the repair of this machine.
- Immediately tag and remove from service a damaged or malfunctioning machine.
- Repair any machine damage or malfunction before operating the machine.

### Before Repairs Start:

- Read, understand and obey the safety rules and operating instructions in the appropriate operator's manual on your machine.
- Be sure that all necessary tools and parts are available and ready for use.
- Use only Genie approved replacement parts.
- Read each procedure completely and adhere to the instructions. Attempting shortcuts may produce hazardous conditions.

### Machine Configuration:

- Unless otherwise specified, perform each repair procedure with the machine in the following configuration:
  - Machine parked on a firm, level surface
  - Key switch in the off position with the key removed
  - The red Emergency Stop button in the off position at both ground and platform controls
  - Wheels chocked
  - All external AC power supply disconnected from the machine
  - Boom in the stowed position
  - Turntable secured with the turntable rotation lock

# Repair Procedures

## About This Section

Most of the procedures in this section should only be performed by trained service professional in a suitably equipped workshop. Select the appropriate repair procedure after troubleshooting the problem.

Perform disassembly procedures to the point where repairs can be completed. Then to re-assemble, perform the disassembly steps in reverse order.

## Symbols Legend



Safety alert symbol—used to alert personnel to potential personal injury hazards. Obey all safety messages that follow this symbol to avoid possible injury or death.



Indicates a imminently hazardous situation which, if not avoided, will result in death or serious injury.



Indicates a potentially hazardous situation which, if not avoided, could result in death or serious injury.



Indicates a potentially hazardous situation which, if not avoided, may cause minor or moderate injury.



Indicates a potentially hazardous situation which, if not avoided, may result in property damage.

- ⦿ Indicates that a specific result is expected after performing a series of steps.
- ⊗ Indicates that an incorrect result has occurred after performing a series of steps.

# Platform Controls

## 1-1 Controllers

The drive joystick is connected to the drive motor controller, located under the drive chassis cover at the non-steer end of the machine. Maintaining the boom function speed controller at the proper settings is essential to safe machine operation. The boom function speed controller should operate smoothly and provide proportional speed control through its entire range of motion. For further information or assistance, contact the Genie Product Support.

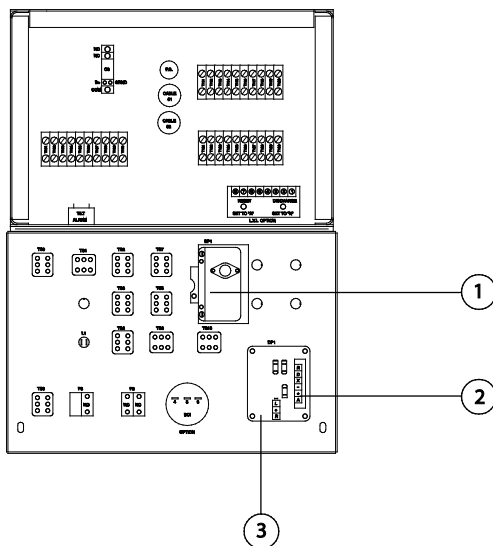

- 1 boom function speed controller
- 2 drive and brake printed circuit board
- 3 drive joystick

## Boom Function Speed Controller Adjustments

**⚠ WARNING** Electrocutation/burn hazard. Contact with electrically charged circuits could result in death or serious injury. Remove all rings, watches and other jewelry.

Note: Do not adjust the boom function speed controller unless the static battery supply voltage is above 24V DC.

- 1 Turn the key switch to platform controls and pull out the red Emergency Stop button to the on position at both the ground and platform controls.
- 2 Open the platform control box lid and locate the boom function speed controller.

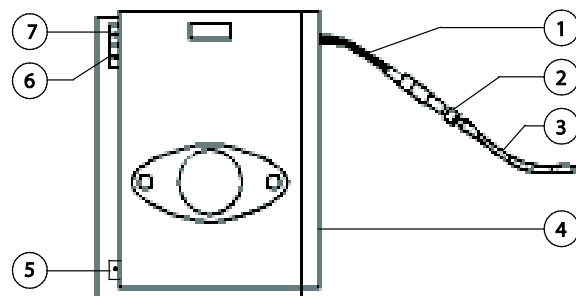

- 1 black/red wire
- 2 diode
- 3 white/red wire
- 4 boom function speed controller
- 5 ramp rate trimpot
- 6 threshold trimpot
- 7 max out trimpot

## Platform Controls

- 3 Locate the diode between the black/red wire from the boom function speed controller and the white/red wire. Disconnect the white/red wire from the diode on the black/red wire.
- 4 Connect the negative lead from a multimeter set to measure amperage to the wire connector of the white/red wire. Connect the positive lead of the multimeter to the diode on the black/red wire.
- 5 Turn the boom function speed controller to the creep position.
- 6 Set the threshold: Press down the foot switch and move the primary boom toggle switch to the up position. Adjust the amperage to 0.28A. Turn the threshold trimpot adjustment screw clockwise to increase the amperage or counterclockwise to decrease the amperage.
- 7 Turn the boom function speed controller to the 9 position.
- 8 Set the max out: Press down the foot switch and move the primary boom toggle switch to the down position. Adjust the amperage to 0.65A. Turn the max out trimpot adjustment screw clockwise to increase the amperage or counterclockwise to decrease the amperage.
- 9 Start a timer and simultaneously press down the foot switch and move the primary boom toggle switch in the down direction. Note how long it takes to reach 0.65A.
- 10 Set the ramp rate: Turn the ramp rate trimpot to obtain a 2 second delay from 0 to 0.65A. Turn the trimpot clockwise to increase the time or counterclockwise to decrease the time.
- 11 Disconnect the leads from the multimeter and connect the white/red wire to the diode on the black/red wire.

---

### Boom function speed controller specifications

---

Threshold (controller turned to creep)	0.28A
Max out (controller turned to 9)	0.65A
Ramp rate	2 seconds

---

## Platform Components

### 2-1 Platform Leveling Slave Cylinder

The slave cylinder and the rotator pivot are the two primary supports for the platform. The slave cylinder keeps the platform level through the entire range of boom motion. It operates in a closed-circuit hydraulic loop with the master cylinder. The slave cylinder is equipped with counterbalance valves to prevent movement in the event of a hydraulic line failure.

#### How to Remove the Platform Leveling Slave Cylinder

Note: Before cylinder removal is considered, bleed the slave cylinder to be sure there is no air in the closed loop.

Note: When removing a hose assembly or fitting, the O-ring (if equipped) on the fitting and/or hose end must be replaced. All connections must be torqued to specification during installation. Refer to Specifications, *Hydraulic Hose and Fitting Torque Specifications*.

- 1 Extend the boom until the slave cylinder barrel-end pivot pin is accessible.
- 2 Raise the boom slightly and place blocks under the platform for support. Lower the boom until the platform is resting on the blocks.

- 3 Tag and disconnect the hydraulic hoses to the slave cylinder at the union and connect them together with a connector. Cap the fittings on the cylinder hoses.

**▲ WARNING** Bodily injury hazard. Spraying hydraulic oil can penetrate and burn skin. Loosen hydraulic connections very slowly to allow the oil pressure to dissipate gradually. Do not allow oil to squirt or spray.

- 4 Remove the external snap rings from the rod-end pivot pin. Do not remove the pin.
- 5 Remove the external snap rings from the barrel-end pivot pin.
- 6 Place a block of wood under the barrel of the slave cylinder for support.
- 7 Use a soft metal drift to remove the rod-end pivot pin.

**▲ WARNING** Crushing hazard. The platform could fall if not properly supported.

- 8 Use a soft metal drift to remove the barrel-end pivot pin.
- 9 Carefully pull the cylinder with hydraulic hoses out of the boom.

#### How to Bleed the Slave Cylinder

- 1 Raise the jib boom to a horizontal position.
- 2 Move the platform level toggle switch up and down through two platform leveling cycles to remove any air that might be in the system.

## Platform Components

### 2-2 Platform Rotator

#### How to Remove the Platform Rotator

Note: When removing a hose assembly or fitting, the O-ring (if equipped) on the fitting and/or hose end must be replaced. All connections must be torqued to specification during installation. Refer to Specifications, *Hydraulic Hose and Fitting Torque Specifications*.

- 1 Remove the platform.
- 2 Tag, disconnect and plug the hydraulic hoses from the platform rotate manifold.

**▲WARNING** Bodily injury hazard. Spraying hydraulic oil can penetrate and burn skin. Loosen hydraulic connections very slowly to allow the oil pressure to dissipate gradually. Do not allow oil to squirt or spray.

- 3 Support the platform mounting weldment. Do not apply any lifting pressure.
- 4 Remove the six mounting bolts from the platform mounting weldment. Remove the center bolt and slide the platform mounting weldment off of the platform rotator.
- 5 Support the platform rotator with a suitable lifting device. Do not apply any lifting pressure.
- 6 Remove the pin retaining fasteners from the jib boom and leveling links to platform rotator pivot pins. Do not remove the pins.

- 7 Support the jib boom, jib boom cylinder and leveling links with an overhead crane.
- 8 Use a soft metal drift to drive both pins out, then remove the platform rotator from the machine.

**▲WARNING** Crushing hazard. The platform rotator could fall when removed from the machine if not properly supported.

Note: When installing the platform rotator, be sure to torque the fasteners to specification. Refer to Specifications, *Machine Torque Specifications*.

#### How to Bleed the Platform Rotator

Note: This procedure will require two people.

- 1 Move the function enable toggle switch to either side and activate the platform rotate toggle switch to the right and then to the left through two platform rotation cycles. Then hold the switch to the right position until the platform is fully rotated to the right.
- 2 Place a suitable container underneath the platform rotator.
- 3 Open the top bleed screw on the rotator, but do not remove it.

**▲WARNING** Bodily injury hazard. Spraying hydraulic oil can penetrate and burn skin. Loosen hydraulic connections very slowly to allow the oil pressure to dissipate gradually. Do not allow oil to squirt or spray.



## Platform Components

- 4 Move the function enable toggle switch to either side and hold the platform rotate toggle switch to the left position until the platform is fully rotated to the left. Continue holding the toggle switch until air stops coming out of the bleed screw. Close the bleed screw.

**⚠ WARNING** Crushing hazard. Keep clear of the platform during rotation.

- 5 Open the bottom bleed screw on the rotator, but do not remove it.

**⚠ WARNING** Bodily injury hazard. Spraying hydraulic oil can penetrate and burn skin. Loosen hydraulic connections very slowly to allow the oil pressure to dissipate gradually. Do not allow oil to squirt or spray.

- 6 Move the function enable toggle switch to either side and hold the platform rotate toggle switch to the right position until the platform is fully rotated to the right. Continue holding the toggle switch until air stops coming out of the bleed screw. Close the bleed screw.

**⚠ WARNING** Crushing hazard. Keep clear of the platform during rotation.

- 7 Clean up any hydraulic oil that may have spilled.
- 8 Rotate the platform fully in both directions and inspect the bleed screws for leaks.

### 2-3

## Platform Overload System

### How to Calibrate the Platform Overload System

Calibration of the platform overload system is essential to safe machine operation. Continued use of an improperly calibrated platform overload system could result in the system failing to sense an overloaded platform. The stability of the machine is compromised and it could tip over.

Note: Perform this procedure with the machine on a firm, level surface.

- 1 Turn the key switch to platform control.
- 2 Determine the maximum platform capacity. Refer to the machine serial plate.
- 3 Remove all weight, tools and accessories from the platform.

Note: Failure to remove all weight, tools and accessories from the platform will result in an incorrect calibration.

- 4 Using a suitable lifting device, place a test weight equal to the maximum platform capacity at the center of the platform floor.

## Platform Components

5 Move the platform up and down by hand, so it bounces approximately 2.5 to 5 cm / 1 to 2 inches. Allow the platform to settle.

⦿ Result: The overload indicator lights are off and the alarm does not sound. Proceed to step 6.

⊗ Result: The overload indicator lights are flashing at the platform and ground controls, and the alarm is sounding. Slowly tighten the load spring adjustment nut in a clockwise direction in 10° increments until the overload indicator light turns off, and the alarm does not sound. Proceed to step 8.

Note: The platform will need to be moved up and down and allowed to settle between each adjustment.

Note: There may be a 2 second delay before the platform overload indicator light and alarm responds.

6 Move the platform up and down by hand, so it bounces approximately 2.5 to 5 cm / 1 to 2 inches. Allow the platform to settle.

⦿ Result: The overload indicator lights are off at the platform and ground controls, and the alarm does not sound. Slowly loosen the load spring adjustment nut in a counterclockwise direction in 10° increments until the overload indicator light flashes at both the platform and ground controls, and the alarm sounds. Proceed to step 7.

⊗ Result: The overload indicator lights are flashing at the platform and ground controls, and the alarm is sounding. Repeat this procedure beginning with step 5.

Note: The platform will need to be moved up and down and allowed to settle between each adjustment.

Note: There may be a 2 second delay before the platform overload indicator lights and alarm responds.

7 Move the platform up and down by hand, so it bounces approximately 2.5 to 5 cm / 1 to 2 inches. Allow the platform to settle.

⦿ Result: The overload indicator lights are off and the alarm does not sound. Proceed to step 8.

⊗ Result: The overload indicator lights are flashing at the platform and ground controls, and the alarm is sounding. Repeat this procedure beginning with step 5.

Note: There may be a 2 second delay before the platform overload indicator light and alarm responds.

8 Add an additional 10 lb / 4.5 kg test weight to the platform.

⦿ Result: The overload indicator light is flashing at both the ground and platform controls, and the alarm is sounding. Proceed to step 9.

⊗ Result: The overload indicator light is off at both the ground and platform controls, and the alarm does not sound. Remove the additional 10 lb / 4.5 kg test weight. Repeat this procedure beginning with step 6.

Note: There may be a 2 second delay before the platform overload indicator light and alarm responds.

---

## Platform Components

- 9 Test all machine functions from the platform controls.
    - ⦿ Result: All platform control functions should not operate.
  - 10 Turn the key switch to ground control.
  - 11 Test all machine functions from the ground controls.
    - ⦿ Result: All ground control functions should not operate.
  - 12 Using a suitable lifting device, lift the test weight off the platform floor.
    - ⦿ Result: The platform overload indicator light should be off at both the ground and platform controls and the alarm should not sound.
- Note: There may be a 2 second delay before the overload indicator lights and alarm turn off.
- 13 Test all machine functions from the ground controls.
    - ⦿ Result: All ground control functions should operate normally.
  - 14 Turn the key switch to platform control.
  - 15 Test all machine functions from the platform controls.
    - ⦿ Result: All platform control functions should operate normally.

# Jib Boom Components

## 3-1 Jib Boom

### How to Remove the Jib Boom

Note: Perform this procedure with the boom in the stowed position.

Note: When removing a hose assembly or fitting, the O-ring (if equipped) on the fitting and/or hose end must be replaced. All connections must be torqued to specification during installation. Refer to Specifications, *Hydraulic Hose and Fitting Torque Specifications*.

- 1 Remove the platform.
- 2 Remove the platform mounting weldment and the platform rotator. See Repair procedure, *How to Remove the Platform Rotator*
- 3 Tag, disconnect and plug the jib boom lift cylinder hydraulic hoses. Cap the fittings on the jib boom lift cylinder.
- 4 Remove the cable cover from the side of the jib boom.
- 5 Remove the mounting fasteners from the jib boom/platform rotate manifold and lay the manifold to the side. Do not remove the hoses or disconnect the wiring.

**NOTICE** Component damage hazard. Hoses can be damaged if they are kinked or pinched.

- 6 **Models with rotating jib boom:** Tag, disconnect and plug the hydraulic hoses from the jib boom rotator. Cap the fittings on the rotator manifold.

**WARNING** Bodily injury hazard. Spraying hydraulic oil can penetrate and burn skin. Loosen hydraulic connections very slowly to allow the oil pressure to dissipate gradually. Do not allow oil to squirt or spray.

- 7 Attach a lifting strap from an overhead crane to the jib boom.
- 8 **Models without rotating jib boom:** Remove the pin retaining fastener from the jib boom pivot pin at the jib boom bellcrank. Use a soft metal drift to remove the pin, then remove the jib boom from the jib boom bellcrank.

**WARNING** Crushing hazard. The jib boom could fall when the pin is removed if not properly supported by the overhead crane.

**Models with rotating jib boom:** Remove the pin retaining fastener from the jib boom pivot pin at the jib boom rotator. Use a soft metal drift to remove the pin, then remove the jib boom from the jib boom rotator.

**WARNING** Crushing hazard. The jib boom could fall when the pin is removed if not properly supported by the overhead crane.

## Jib Boom Components

- 9 Remove the pin retaining fasteners from the jib boom lift cylinder rod-end pivot pin. Do not remove the pin.
- 10 **Models without rotating jib boom:** Remove both of the jib boom leveling links from the bell crank.
- Models with rotating jib boom:** Remove both of the jib boom leveling links from the jib boom rotator.
- 11 Attach a lifting strap from an overhead crane to the rod-end of the jib boom lift cylinder.
- 12 **Models without rotating jib boom:** Use a soft metal drift to remove the jib boom lift cylinder rod-end pivot pin. Remove the jib boom lift cylinder from the bell crank.

**Models with rotating jib boom:** Use a soft metal drift to remove the jib boom lift cylinder rod-end pivot pin. Remove the jib boom lift cylinder from the jib boom rotator.

**⚠ WARNING** Crushing hazard. The jib boom lift cylinder may become unbalanced and fall when it is removed from the machine if it is not properly supported by the overhead crane.

### 3-2

#### Jib Boom Bell Crank (models without rotating jib boom)

---

#### How to Remove the Jib Boom Bell Crank

Note: Perform this procedure with the boom in the stowed position.

Note: When removing a hose assembly or fitting, the O-ring (if equipped) on the fitting and/or hose end must be replaced. All connections must be torqued to specification during installation. Refer to Specifications, *Hydraulic Hose and Fitting Torque Specifications*.

- 1 Remove the jib boom. Refer to Repair Procedure, *How to Remove the Jib Boom*.
- 2 Support and secure the jib boom bell crank to an appropriate lifting device.
- 3 Remove the pin retaining fasteners from the slave cylinder rod-end pivot pin. Do not remove the pin.
- 4 Place a block of wood under the platform leveling slave cylinder for support. Protect the cylinder rod from damage.
- 5 Remove the pin retaining fasteners from the jib boom bell crank at the extension boom. Use a soft metal drift to remove the pin.
- 6 Use a soft metal drift to remove the slave cylinder rod-end pivot pin.
- 7 Remove the jib boom bell crank from the extension boom.

**⚠ WARNING** Crushing hazard. The jib boom bellcrank may become unbalanced and fall if it is not properly supported when it is removed from the machine.

## Jib Boom Components

### 3-3 Jib Boom Rotator (models with rotating jib boom)

The platform rotator is a hydraulically activated helical gear assembly used to rotate the jib boom 160 degrees.

#### How to Remove the Jib Boom Rotator

Note: When removing a hose assembly or fitting, the O-ring (if equipped) on the fitting and/or hose end must be replaced. All connections must be torqued to specification during installation. Refer to Specifications, *Hydraulic Hose and Fitting Torque Specifications*.

- 1 Remove the jib boom. Refer to Repair Procedure, *How to Remove the Jib Boom*.
- 2 Support and secure the jib boom rotator to an appropriate lifting device.
- 3 Remove the eight mounting bolts from the jib boom rotator mount.
- 4 Remove the center bolt. Carefully remove the jib boom rotator from the machine.

**⚠ WARNING** Crushing hazard. The jib boom rotator could become unbalanced and fall when removed from the machine if not properly supported and secured to the lifting device.

Note: When installing the jib boom rotator, be sure to torque the fasteners to specification. Refer to Specifications, *Machine Torque Specifications*.

- 5 Support and secure the jib boom bell crank to an appropriate lifting device.

- 6 Remove the pin retaining fasteners from the slave cylinder rod-end pivot pin. Do not remove the pin.
- 7 Place a block of wood under the platform leveling slave cylinder for support. Protect the cylinder rod from damage.
- 8 Remove the pin retaining fasteners from the jib boom bell crank at the extension boom. Use a soft metal drift to remove the pin.
- 9 Use a soft metal drift to remove the slave cylinder rod-end pivot pin.
- 10 Remove the jib boom bell crank from the extension boom.

**⚠ WARNING** Crushing hazard. The jib boom bellcrank may become unbalanced and fall if it is not properly supported when it is removed from the machine.

#### How to Bleed the Jib Boom Rotator

Note: This procedure will require two people.

- 1 Turn the key switch to ground controls and pull out the red Emergency Stop buttons to the on position at both the ground and platform controls.

## Jib Boom Components

- 2 Connect a clear hose to the top bleed valve. Place the other end of the hose in a container to collect any drainage. Open the top bleed valve, but do not remove it.

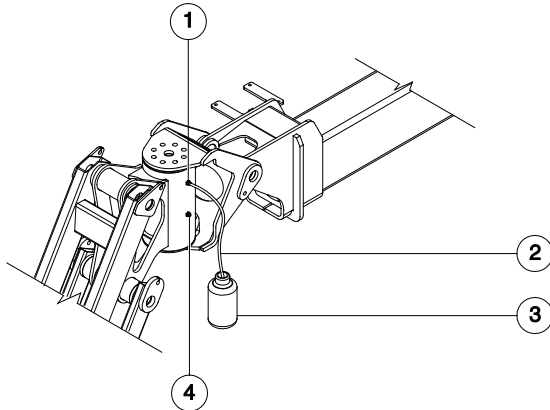

- 1 top bleed valve
- 2 clear hose
- 3 container
- 4 bottom bleed valve

- 3 Move and hold the function enable toggle switch to either side and move and hold the jib boom rotate toggle switch to the right for approximately 5 seconds, then release it. Repeat three times.

**⚠ WARNING** Crushing hazard. Keep hands and head clear of the platform pivot weldment during rotation.

- 4 Move and hold the function enable switch to either side and move and hold the jib boom rotate toggle switch to the left for approximately 5 seconds, then release it. Repeat three times.

- 5 Fully rotate the jib boom to the left and continue holding the jib boom rotate toggle switch until air stops coming out of the bleed valve. Immediately release the platform rotate toggle switch and close the bleed valve.

**⚠ WARNING** Crushing hazard. Keep hands and head clear of the platform pivot weldment during rotation.

- 6 Rotate the jib boom to the right until the jib boom is centered.
- 7 Connect the clear hose to the bottom bleed valve and open the valve.
- 8 Rotate the jib boom to the right and continue holding the platform rotate toggle switch until air stops coming out of the bleed valve.

**⚠ WARNING** Crushing hazard. Keep hands and head clear of the jib boom during rotation.

- 9 Close the bleed valve and remove the hose.
- 10 Rotate the jib boom full left and right and inspect the bleed valves for leaks.

**⚠ WARNING** Crushing hazard. Keep hands and head clear of the platform pivot weldment during rotation.

- 11 Turn the key switch to the off position and clean up any hydraulic oil that may have spilled.

## Jib Boom Components

### 3-4 Jib Boom Lift Cylinder

#### How to Remove the Jib Boom Lift Cylinder

Note: Perform this procedure with the boom in the stowed position.

Note: When removing a hose assembly or fitting, the O-ring (if equipped) on the fitting and/or hose end must be replaced. All connections must be torqued to specification during installation. Refer to Specifications, *Hydraulic Hose and Fitting Torque Specifications*.

- 1 Raise the jib boom slightly and place blocks under the platform mounting weldment. Then lower the jib boom until the platform is resting on the blocks just enough to support the platform.

Note: Do not rest the entire weight of the boom on the blocks.

- 2 Tag, disconnect and plug the jib boom lift cylinder hydraulic hoses. Cap the fittings on the cylinder.

**⚠ WARNING** Bodily injury hazard. Spraying hydraulic oil can penetrate and burn skin. Loosen hydraulic connections very slowly to allow the oil pressure to dissipate gradually. Do not allow oil to squirt or spray.

- 3 Remove the pin retaining fasteners from the jib boom lift cylinder rod-end pivot pin. Do not remove the pin.
- 4 Use a soft metal drift to tap the rod-end pivot pin half way out and lower one of the leveling links to the ground. Tap the pin the other direction and lower the opposite leveling link. Do not remove the pin.
- 5 Attach a lifting strap from an overhead crane to the rod end of the jib boom lift cylinder.
- 6 Remove the pin retaining fasteners from the jib boom lift cylinder barrel-end pivot pin. Use a soft metal drift to remove the barrel-end pivot pin.
- 7 Use a soft metal drift to remove the jib boom lift cylinder rod-end pivot pin. Remove the jib boom lift cylinder from the machine.

**⚠ WARNING** Crushing hazard. The jib boom lift cylinder may become unbalanced and fall when it is removed from the machine if it is not properly supported by the overhead crane.



## Primary Boom Components

### 4-1 Cable Track

The primary boom cable track guides the cables and hoses running up the boom. It can be repaired link by link without removing the cables and hoses that run through it. Removing the entire primary boom cable track is only necessary when performing major repairs that involve removing the primary boom.

### How to Repair the Primary Boom Cable Track

#### NOTICE

Component damage hazard.  
The boom cable track can be damaged if it is twisted.

Note: A 7 link repair section of cable track is available through the Genie Service Parts Department.

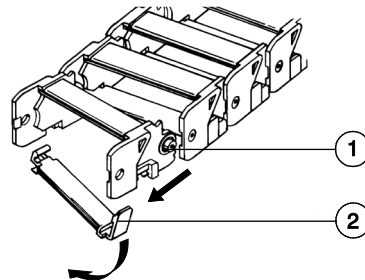

- 1 link separation point
- 2 lower clip

- 1 Use a slotted screwdriver to pry down on the lower clip.
- 2 To remove a single link, open the lower clip and then use a screw driver to pry the link to the side.
- 3 Repeat steps 1 and 2 for each link.

## Primary Boom Components

### How to Shim the Primary Boom

- 1 Extend the boom until the wear pads are accessible.
- 2 Loosen the wear pad mounting fasteners.
- 3 Install the new shims under the wear pad to obtain zero clearance and zero drag.
- 4 Tighten the mounting fasteners.
- 5 Extend and retract the boom through an entire cycle. Check for tight spots that could cause scraping or binding.

Note: Always maintain squareness between the outer and inner boom tubes.

### How to Remove the Primary Boom

#### **⚠ WARNING**

Bodily injury hazard. This procedure requires specific repair skills, lifting equipment and a suitable workshop. Attempting this procedure without these skills and tools could result in death or serious injury and significant component damage. Dealer service is strongly recommended.

Note: Perform this procedure with the boom in the stowed position.

Note: When removing a hose assembly or fitting, the O-ring (if equipped) on the fitting and/or hose end must be replaced. All connections must be torqued to specification during installation. Refer to Specifications, *Hydraulic Hose and Fitting Torque Specifications*.

- 1 Remove the platform.
- 2 Remove the platform rotator. Refer to Repair Procedure, *How to Remove the Platform Rotator*.
- 3 Remove the jib boom. Refer to Repair Procedure, *How to Remove the Jib Boom*.
- 4 **Models without rotating jib boom:** Remove the jib boom bellcrank. Refer to Repair Procedure, *How to Remove the Jib Boom Bellcrank*.

**Models with rotating jib boom:** Remove the jib boom rotator. Refer to Repair Procedure, *How to Remove the Jib Boom Rotator*.

## Primary Boom Components

- 5 Tag, disconnect and cap the slave cylinder hydraulic hoses at the union. Plug the hoses from the slave cylinder.

**WARNING** Bodily injury hazard. Spraying hydraulic oil can penetrate and burn skin. Loosen hydraulic connections very slowly to allow the oil pressure to dissipate gradually. Do not allow oil to squirt or spray.

- 6 Remove the upper cable track mounting fasteners from the platform end of the boom.
- 7 Remove the cable track mounting fasteners, then remove the cable track from the boom and lay it flat on the ground.

**NOTICE** Component damage hazard. The boom cable track can be damaged if it is twisted.

**NOTICE** Component damage hazard. Hoses can be damaged if they are kinked or pinched.

- 8 Raise the secondary boom until the primary boom lift cylinder rod-end pivot pin is accessible above the mid-pivot weldment. Turn the machine off.
- 9 Disconnect the battery packs from the machine.
- 10 Remove all the hose and cable clamps from the underside of the primary boom and at the pivot end of the primary boom.
- 11 Attach a lifting strap of ample capacity from an overhead 5 ton / 5000 kg crane to the primary boom for support.

- 12 Locate the cables from the primary boom cable track to the platform control box. Number each cable and its entry location at the platform control box.
- 13 Open the platform control box.
- 14 Tag and disconnect each wire from the cables in the platform control box.
- 15 Pull all the cables out of the platform control box.
- 16 Remove the front counterweight cover.
- 17 Remove the extension boom drive limit switch from the side of the primary boom at the pivot end. Do not disconnect the wiring.
- 18 Tag, disconnect and plug the hydraulic hoses from the jib boom/platform rotate manifold.
- 19 Pull all the electrical cables and hydraulic hoses out of the plastic cable track. Then pull all the electrical cables and hydraulic hoses out through the boom rest pad.

**NOTICE** Component damage hazard. Hoses can be damaged if they are kinked or pinched.

- 20 Remove the pin retaining fastener from the master cylinder rod-end pivot pin. Use a soft metal drift to remove the pivot pin. Pull the cylinder back and secure it from moving.
- 21 Tag, disconnect and plug the extension cylinder hydraulic hoses. Cap the fittings on the cylinder.

**WARNING** Bodily injury hazard. Spraying hydraulic oil can penetrate and burn skin. Loosen hydraulic connections very slowly to allow the oil pressure to dissipate gradually. Do not allow oil to squirt or spray.

## Primary Boom Components

- 22 Attach a lifting strap from an overhead crane to the primary boom lift cylinder.
- 23 Place 2 x 4 x 18 inch / 5 x 10 x 46 cm support blocks under the cylinder, across the secondary boom.
- 24 Remove the pin retaining fastener from the primary boom lift cylinder rod-end pivot pin. Use a soft metal drift to remove the pin.

**⚠ WARNING** Crushing hazard. The primary boom lift cylinder could become unbalanced and fall if not properly supported by the lifting device.

- 25 Lower the rod end of the primary boom lift cylinder onto support blocks. Protect the cylinder rod from damage.
- 26 Remove the pin retaining fastener from the primary boom pivot pin.
- 27 Remove the primary boom pivot pin with a soft metal drift. Carefully remove the primary boom assembly from the machine.

**⚠ WARNING** Crushing hazard. The primary boom could become unbalanced and fall when removed from the machine if not properly attached to the overhead crane.

## How to Disassemble the Primary Boom

Note: Complete disassembly of the boom is only necessary if the outer or inner boom tubes must be replaced. The extension cylinder can be removed without completely disassembling the boom. Refer to Repair Procedure, *How to Remove the Extension Cylinder*.

- 1 Remove the primary boom. Refer to Repair Procedure, *How to Remove the Primary Boom*.
- 2 Place blocks under the extension cylinder for support.
- 3 Remove the retaining fasteners from the extension cylinder barrel-end pivot pin. Use a soft metal drift to remove the pin.
- 4 Remove and label the location of the wear pads from the top side of the boom tube at the platform end of the boom.

Note: Pay careful attention to the location and amount of shims used with each wear pad.

- 5 Support the extension tube with an overhead crane at the platform end of the boom.

**⚠ WARNING** Crushing hazard. The boom extension tube could fall when removed from the boom if not properly supported.

## Primary Boom Components

- 6 Support and slide the extension tube out of the primary boom tube. Place the extension tube on blocks for support.

Note: During removal, the overhead crane strap will need to be adjusted for proper balancing.

- 7 Remove the external snap rings from the slave cylinder barrel-end pivot pin.
- 8 Use a soft metal drift and drive the slave cylinder barrel-end pivot pin out.
- 9 Remove the slave cylinder from the primary extension boom tube.
- 10 Remove the external snap rings from the extension cylinder rod-end pivot pins at the platform end of the extension tube. Use a soft metal drift to remove the pins.
- 11 Support and slide the extension cylinder out of the pivot end of the boom extension tube. Place the extension cylinder on blocks for support.

Note: During removal, the overhead crane strap will need to be adjusted for proper balancing.

### 4-3

#### Primary Boom Lift Cylinder

The primary boom lift cylinder raises and lowers the primary boom. The primary boom lift cylinder is equipped with a counterbalance valve to prevent movement in the event of a hydraulic line failure.

#### How to Remove the Primary Boom Lift Cylinder

**▲ WARNING** Bodily injury hazard. This procedure requires specific repair skills, lifting equipment and a suitable workshop. Attempting this procedure without these skills and tools could result in death or serious injury and significant component damage. Dealer service is strongly recommended.

Note: When removing a hose assembly or fitting, the O-ring (if equipped) on the fitting and/or hose end must be replaced. All connections must be torqued to specification during installation. Refer to Specifications, *Hydraulic Hose and Fitting Torque Specifications*.

- 1 Raise the secondary boom enough to access the primary boom lift cylinder barrel-end pivot pin.
- 2 Raise the primary boom enough to access the primary boom lift cylinder rod-end pivot pin.

## Primary Boom Components

- 3 Support the primary boom lift cylinder with a suitable lifting device. Place a block of wood across the upper secondary boom to support the cylinder when the rod-end pin is removed.
- 4 Attach an overhead crane to the primary boom at the platform end for support. Raise the primary boom using the overhead crane just enough to relieve the pressure on the primary boom lift cylinder rod-end pivot pin.
- 5 Remove the counterweight cover fasteners. Remove the counterweight cover from the machine.
- 6 Place a block of wood between the counterweight plate on the leveling link and the cross member of the upper secondary boom. Carefully lower the secondary boom onto the block.
 

**⚠ WARNING** Crushing hazard. Keep hands away from the block and all moving parts when lowering the secondary boom onto the block.
- 7 Remove the pin retaining fasteners from the primary boom lift cylinder rod-end pivot pin. Use a soft metal drift to remove the pin.
 

**⚠ WARNING** Crushing hazard. The primary boom lift cylinder could become unbalanced and fall if not properly supported by the lifting device.
- 8 Lower the rod end of the cylinder onto the blocks that were placed on the upper secondary boom.
- 9 Remove the pin retaining fastener from the ground control side upper secondary leveling link pivot pin at the upper pivot (same side of machine as the primary boom lift cylinder barrel-end pivot pin retainer).
- 10 Place a rod through the upper secondary leveling link pivot pin at the upper pivot and twist to remove the pin.
- 11 Swing the leveling link up out of the way and secure it from moving.
- 12 Tag, disconnect and plug the primary boom lift cylinder hydraulic hoses. Cap the fittings on the cylinder.
 

**⚠ WARNING** Bodily injury hazard. Spraying hydraulic oil can penetrate and burn skin. Loosen hydraulic connections very slowly to allow the oil pressure to dissipate gradually. Do not allow oil to squirt or spray.
- 13 Support the barrel end of the primary boom lift cylinder with straps or ropes to restrict it from swinging freely.
- 14 Remove the pin retaining fastener from the primary boom lift cylinder barrel-end pivot pin. Do not remove the pivot pin.

## Primary Boom Components

- 15 Place a rod through the barrel-end pivot pin and twist to remove the pin.

**⚠ WARNING** Crushing hazard. The primary boom lift cylinder could become unbalanced and fall if not properly supported by the lifting device.

- 16 Attach an overhead crane or similar lifting device to the lug on the rod-end of the primary boom lift cylinder. Carefully loosen the straps and allow the primary boom lift cylinder to slowly swing down.

- 17 Carefully remove the cylinder from the machine.

**⚠ WARNING** Crushing hazard. The primary boom lift cylinder could become unbalanced and fall if not properly supported by the lifting device.

### 4-4

## Primary Boom Extension Cylinder

The primary boom extension cylinder extends and retracts the primary boom extension tube. The primary boom extension cylinder is equipped with counterbalance valves to prevent movement in the event of a hydraulic line failure.

## How to Remove the Primary Boom Extension Cylinder

**⚠ WARNING** Bodily injury hazard. This procedure requires specific repair skills, lifting equipment and a suitable workshop. Attempting this procedure without these skills and tools could result in death or serious injury and significant component damage. Dealer service is strongly recommended.

Note: When removing a hose assembly or fitting, the O-ring (if equipped) on the fitting and/or hose end must be replaced. All connections must be torqued to specification during installation. Refer to Specifications, *Hydraulic Hose and Fitting Torque Specifications*.

- 1 Raise the primary boom to a horizontal position.
- 2 Extend the primary boom until the primary boom extension cylinder rod-end pivot pin is accessible in the primary boom extension tube.

## Primary Boom Components

- 3 Remove the external snap rings from the extension cylinder rod-end pivot pins. Use a soft metal drift to remove the pins.
  - 4 Remove the counterweight cover fasteners. Remove the counterweight cover from the machine.
  - 5 Raise the secondary boom until the master cylinder rod-end pivot pin is accessible.
  - 6 Remove the primary boom extend drive limit switch from the pivot end of the primary boom. Do not disconnect the wiring.
  - 7 Remove the retaining fastener from the master cylinder rod-end pivot pin. Use a soft metal drift to remove the pin.
  - 8 Manually retract the master cylinder and push it toward the platform end of the boom to obtain enough clearance for extension cylinder removal.
  - 9 Tag, disconnect and plug the primary boom extension cylinder hydraulic hoses. Cap the fittings on the cylinder.
- ⚠ WARNING** Bodily injury hazard. Spraying hydraulic oil can penetrate and burn skin. Loosen hydraulic connections very slowly to allow the oil pressure to dissipate gradually. Do not allow oil to squirt or spray.
- 10 Remove the retaining fastener from the extension cylinder barrel-end pivot pin. Use a soft metal drift to remove the pin.
  - 11 Carefully pull out and properly support the extension cylinder from the primary boom with a lifting strap from an overhead crane.
- ⚠ WARNING** Crushing hazard. The extension cylinder could fall when removed from the extension boom if not properly supported.
- NOTICE** Component damage hazard. Be careful not to damage the counterbalance valves on the primary boom extension cylinder when removing the cylinder from the primary boom.
- NOTICE** Component damage hazard. Hoses and cables can be damaged if the primary boom extension cylinder is dragged across them.
- Note: Note the length of the cylinder after removal. The cylinder must be at the same length for installation.



## Primary Boom Components

### 4-5 Platform Leveling Master Cylinder

The platform leveling master cylinder acts as a pump for the slave cylinder. It is part of the closed-loop hydraulic circuit that keeps the platform level through the entire range of primary boom motion. The platform leveling master cylinder is located inside the upper mid-pivot at the pivot end of the primary boom.

### How to Remove the Platform Leveling Master Cylinder

**▲ WARNING** Bodily injury hazard. This procedure requires specific repair skills, lifting equipment and a suitable workshop. Attempting this procedure without these skills and tools could result in death or serious injury and significant component damage. Dealer service is strongly recommended.

Note: When removing a hose assembly or fitting, the O-ring (if equipped) on the fitting and/or hose end must be replaced. All connections must be torqued to specification during installation. Refer to Specifications, *Hydraulic Hose and Fitting Torque Specifications*.

- 1 Raise the secondary boom until both the rod end and barrel-end pivot pins of the master cylinder are accessible.

- 2 Tag, disconnect and plug the master cylinder hydraulic hoses. Cap the fittings on the cylinder.

**▲ WARNING** Bodily injury hazard. Spraying hydraulic oil can penetrate and burn skin. Loosen hydraulic connections very slowly to allow the oil pressure to dissipate gradually. Do not allow oil to squirt or spray.

- 3 Attach an overhead crane or similar lifting device to the master cylinder.
- 4 Remove the pin retaining fasteners from the master cylinder barrel-end pivot pin. Use a soft metal drift to remove the pin.

**▲ WARNING** Crushing hazard. The master cylinder could become unbalanced and fall if not properly attached to the overhead crane.

- 5 Remove the pin retaining fastener from the rod-end pivot pin.
- 6 Place a rod through the rod-end pivot pin and twist to remove the pin.
- 7 Remove the master cylinder from the machine.

**▲ WARNING** Crushing hazard. The master cylinder could become unbalanced and fall if not properly attached to the overhead crane.

# Secondary Boom Components

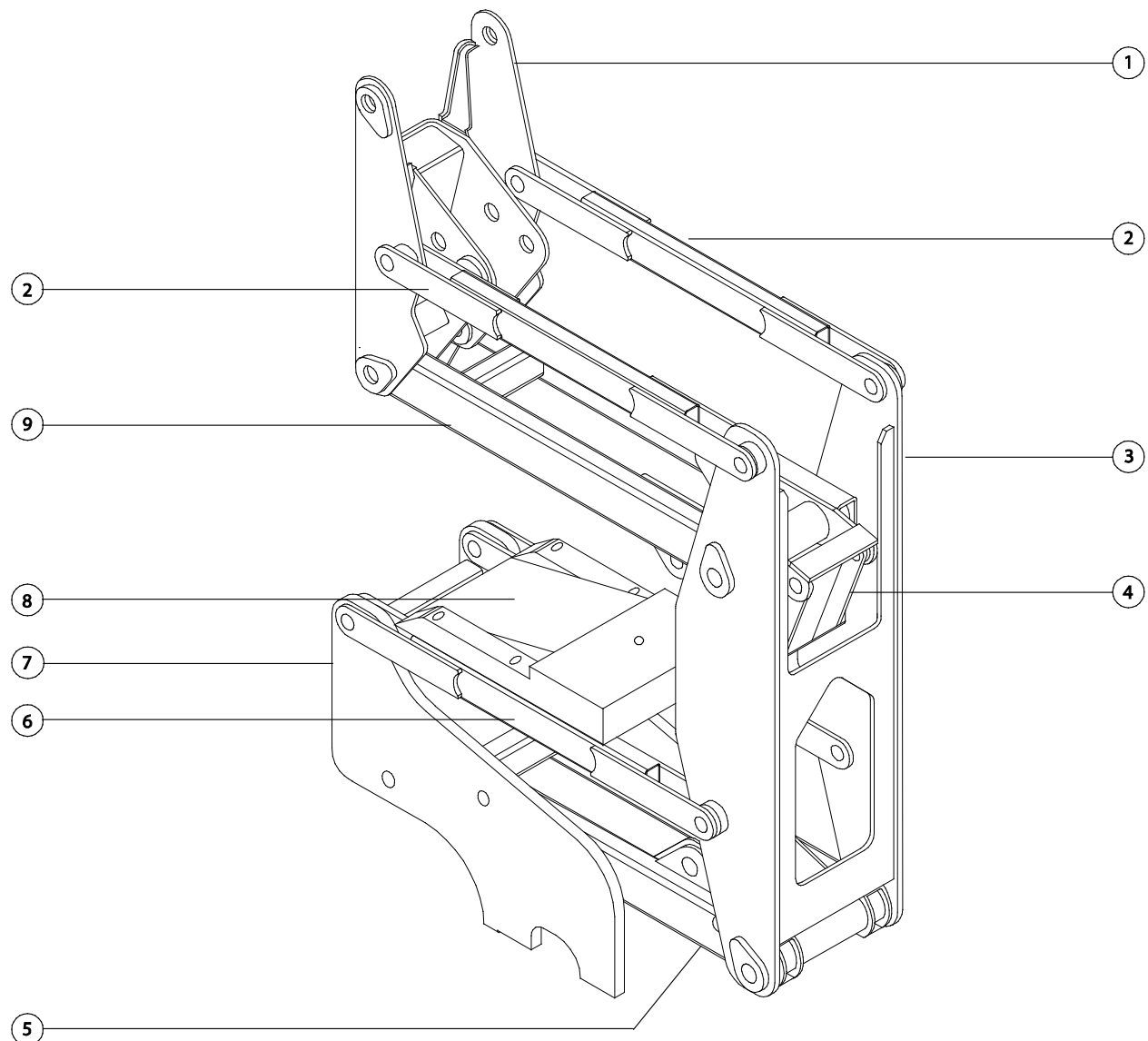

**Secondary Boom components**

- 1 upper pivot
- 2 upper compression arm
- 3 mid-pivot
- 4 compression link
- 5 lower secondary boom
- 6 lower compression arm
- 7 turntable pivot
- 8 counterweight (Z-30N / Z-30N RJ)
- 9 upper secondary boom



## Secondary Boom Components

### 5-1 Secondary Boom

#### How to Disassemble the Secondary Boom

**⚠ WARNING** Bodily injury hazard. This procedure requires specific repair skills, lifting equipment and a suitable workshop. Attempting this procedure without these skills and tools could result in death or serious injury and significant component damage. Dealer service is strongly recommended.

Follow the disassembly steps to the point required to complete the repair. Then re-assemble the secondary boom by following the disassembly steps in reverse order.

Note: When removing a hose assembly or fitting, the O-ring (if equipped) on the fitting and/or hose end must be replaced. All connections must be torqued to specification during installation. Refer to Specifications, *Hydraulic Hose and Fitting Torque Specifications*.

- 1 Remove the counterweight cover.
- 2 Place a suitable lifting device under the platform for support.
- 3 Disconnect the battery packs from the machine.
- 4 Remove the cable cover from the side of the jib boom.

- 5 Remove the wire loom from the cables at the platform control box.
- 6 Locate the cables from the primary boom cable track to the platform control box. Number each cable and its entry location at the platform control box.
- 7 Open the platform control box.
- 8 Tag and disconnect each wire from the cables in the platform control box.

**⚠ WARNING** Electrocutation/burn hazard. Contact with electrically charged circuits could result in death or serious injury. Remove all rings, watches and other jewelry.

- 9 Pull the cables out of the platform control box.
- 10 Pull all of the electrical cables out of the plastic cable track. Do not pull out the hydraulic hoses.
- 11 Remove the hose clamps from the bottom side of the primary boom.
- 12 Tag, disconnect and plug the hydraulic hoses from the "P" and "T" ports at the jib boom/rotate manifold. Cap the fittings on the manifold.

**⚠ WARNING** Bodily injury hazard. Spraying hydraulic oil can penetrate and burn skin. Loosen hydraulic connections very slowly to allow the oil pressure to dissipate gradually. Do not allow oil to squirt or spray.

- 13 Remove the hose clamp from the side of the primary boom at the pivot end.

## Secondary Boom Components

- 14 Remove the primary boom extend drive speed limit switch (LS1) mounted on the side of the primary boom at the pivot end. Do not disconnect the wiring.
- 15 Attach a lifting strap from an overhead crane to the pivot end of the primary boom.
- 16 Carefully lift the secondary and primary boom assembly with the overhead crane until the master cylinder and primary boom lift cylinder hydraulic hoses are accessible.
- 17 Remove the cable covers from the top of the upper secondary boom.
- 18 Tag, disconnect and plug the primary boom lift cylinder and master cylinder hydraulic hoses. Cap the fittings on the cylinders.
- 22 Remove the pin retaining fasteners from the upper pivot to upper secondary compression arm pivot pins. Use a soft metal drift to remove the pins.
- 23 Swing the compression arms down and out of the way. Secure them from moving.
- 24 Remove the pin retaining fasteners from the upper pivot to the upper secondary boom pivot pin. Use a soft metal drift to remove the pin.
- 25 Carefully remove the entire primary boom assembly from the machine (primary boom assembly, jib boom assembly, platform, master cylinder, primary lift cylinder and upper pivot).

**WARNING** Bodily injury hazard. Spraying hydraulic oil can penetrate and burn skin. Loosen hydraulic connections very slowly to allow the oil pressure to dissipate gradually. Do not allow oil to squirt or spray.

- 19 Lower the secondary boom to the fully stowed position.
- 20 Pull all the cables and hoses through the upper pivot.

**NOTICE** Component damage hazard. Hoses can be damaged if they are kinked or pinched.

- 21 Position a lifting strap from the overhead crane approximately 2 feet / 60 cm from the platform end of the primary boom. Measure from the platform end of the primary boom tube.

**WARNING** Crushing hazard. The primary boom assembly could become unbalanced and fall when removed from the machine if not properly supported by the overhead crane. Do not remove the assembly from the machine until it is properly balanced.

Note: During removal, the overhead crane strap will need to be adjusted for proper balancing.

- 26 Place the entire assembly onto a structure capable of supporting it.
- 27 Remove the pin retaining fasteners from the upper secondary compression arm pivot pins. Do not remove the pins.
- 28 Position a lifting strap from an overhead crane at the center of the control box side upper secondary compression arm.

## Secondary Boom Components

- 29 Use a soft metal drift to remove the upper secondary boom compression arm pivot pins and remove the compression arm from the machine. Repeat this step for the hydraulic tank side upper secondary compression arm.

**⚠ WARNING** Crushing hazard. The upper secondary compression arm could become unbalanced and fall when removed from the machine if not properly supported by the overhead crane.

- 30 Close the hydraulic tank shutoff valve. Tag, disconnect and plug the hydraulic hose from the hydraulic tank shutoff valve.

**⚠ WARNING** Bodily injury hazard. Spraying hydraulic oil can penetrate and burn skin. Loosen hydraulic connections very slowly to allow the oil pressure to dissipate gradually. Do not allow oil to squirt or spray.

- 31 Open the valve on the hydraulic tank and drain the oil into a container of suitable capacity. Refer to Section 2, Specifications.

**⚠ CAUTION** Bodily injury hazard. Beware of hot oil. Contact with hot oil may cause severe burns.

- 32 Tag, disconnect and plug the hydraulic hose from the hydraulic tank return filter housing. Cap the fitting on the filter housing.

**⚠ WARNING** Bodily injury hazard. Spraying hydraulic oil can penetrate and burn skin. Loosen hydraulic connections very slowly to allow the oil pressure to dissipate gradually. Do not allow oil to squirt or spray.

**⚠ CAUTION** Bodily injury hazard. Beware of hot oil. Contact with hot oil may cause severe burns.

- 33 Remove the hydraulic tank mounting fasteners. Remove the hydraulic tank from the machine.
- 34 Open the ground controls side turntable cover.
- 35 Remove the terminal strip cover retaining fasteners. Remove the cover.
- 36 Remove the terminal strip retaining fasteners. Do not disconnect the wiring.
- 37 Remove the plastic plug in the bulkhead to access the secondary boom lift cylinder rod-end pivot pin.
- 38 Remove the pin retaining fastener from the rod end of the secondary boom lift cylinder. Use a soft metal drift to remove the pin through the access holes in the bulkheads. Secure the cylinder from moving.
- 39 Remove the pin retaining fastener from the lower pivot pin on the compression link. Use a soft metal drift to remove the pin.

## Secondary Boom Components

- 40 Attach a lifting strap from an overhead crane to the upper secondary boom.
- 41 Remove the pin retaining fastener from the mid-pivot to upper secondary boom pivot pin. Use a soft metal drift to remove the pin.
- 42 Remove the upper secondary boom with compression link from the machine.

**⚠ CAUTION** Crushing hazard. The upper secondary boom with compression link could become unbalanced and fall when removed from the machine if not properly supported by the overhead crane.

- 43 **Z-30N and Z-30N RJ:** Remove the mounting fasteners from the counterweight attached to the lower leveling link.
- 44 **Z-30N and Z-30N RJ:** Attach a lifting strap from an overhead crane to the counterweight. Remove the counterweight from the lower leveling link.

**⚠ DANGER** Tip-over hazard. The counterweight is critical to machine stability. If the counterweight is not installed during reassembly of the machine, the machine will become unstable and tip over.

**⚠ WARNING** Crushing hazard. The counterweight could become unbalanced and fall when removed from the machine if not properly supported by the overhead crane.

- 45 Remove the mounting fasteners from the function manifold and slide the function manifold to the side. This will allow access to the secondary boom lift cylinder barrel-end pivot pin.
- 46 Remove the mounting fasteners from the auxiliary power unit. Do not disconnect the electrical cables or hydraulic hoses.
- 47 Slide the auxiliary power unit to the side to access the other secondary boom lift cylinder barrel-end pivot pin.
- 48 Remove the retaining fasteners from the secondary boom lift cylinder barrel-end pivot pins.
- 49 Attach a lifting strap from an overhead crane to the lug on the rod end of the secondary boom lift cylinder.
- 50 Tag, disconnect and plug the hydraulic hoses from the secondary boom lift cylinder. Cap the fittings on the cylinder.

**⚠ WARNING** Bodily injury hazard. Spraying hydraulic oil can penetrate and burn skin. Loosen hydraulic connections very slowly to allow the oil pressure to dissipate gradually. Do not allow oil to squirt or spray.

## Secondary Boom Components

- 51 Use a slide hammer to remove the barrel-end pivot pins (access the pins from the access holes in the bulkheads, one on each side). Remove the secondary boom lift cylinder from the machine.

**▲ WARNING** Crushing hazard. The secondary boom lift cylinder could become unbalanced and fall when removed from the machine if not properly attached to the overhead crane.

- 52 Attach a lifting strap from an overhead crane to the mid-pivot for support.
- 53 Remove the pin retaining fasteners from the mid-pivot to the lower secondary compression arm pivot pins. Use a slide hammer and remove the pins. Lower the compression arms down.
- 54 Remove the pin retaining fasteners from the mid-pivot to the lower secondary boom pivot pin. Use a soft metal drift to remove the pins.
- 55 Remove the mid-pivot from the machine.

**▲ WARNING** Crushing hazard. The mid-pivot could become unbalanced and fall when removed from the machine if not properly supported by the overhead crane.

- 56 Remove the secondary boom drive speed limit switch (LS4) mounted to the turntable riser on the ground controls side. Do not disconnect the wiring.

- 57 Attach a lifting strap from an overhead crane to the ground control side lower secondary boom compression arm.

- 58 Remove the pin retaining fastener from the lower secondary boom compression arm to turntable riser pivot pin.

- 59 Use a slide hammer and remove the pin. Remove the compression arm from the machine. Repeat for the hydraulic tank side lower secondary boom compression arm.

**▲ WARNING** Crushing hazard. The lower secondary compression arm could become unbalanced and fall when removed from the machine if not properly supported by the overhead crane.

- 60 Attach a lifting strap from an overhead crane to the lower secondary boom.
- 61 Remove the pin retaining fastener from the lower secondary boom to turntable riser pivot pin. Use a soft metal drift to remove the pin.
- 62 Remove the lower secondary boom from the machine.

**▲ WARNING** Crushing hazard. The lower secondary boom could become unbalanced and fall when removed from the machine if not properly supported by the overhead crane.

## Secondary Boom Components

### 5-2 Secondary Boom Lift Cylinder

The secondary boom lift cylinder raises and lowers the secondary boom. The secondary boom lift cylinder is equipped with counterbalance valves to prevent movement in the event of a hydraulic line failure.

### How to Remove the Secondary Boom Lift Cylinder

**▲WARNING** Bodily injury hazard. This procedure requires specific repair skills, lifting equipment and a suitable workshop. Attempting this procedure without these skills and tools could result in death or serious injury and significant component damage. Dealer service is strongly recommended.

Note: When removing a hose assembly or fitting, the O-ring (if equipped) on the fitting and/or hose end must be replaced. All connections must be torqued to specification during installation. Refer to Specifications, *Hydraulic Hose and Fitting Torque Specifications*.

- 1 Rotate the turntable to either side until the boom is centered between the steer and non-steer tires.
- 2 Raise the primary boom to full height. Do not extend it.
- 3 Swing out the battery pack that is directly below the secondary boom lift cylinder.

- 4 Disconnect the battery packs from the machine.
- 5 Open the hydraulic tank side turntable cover.
- 6 Tag and disconnect the power cables on the auxiliary power unit.

**▲WARNING** Electrocutation/burn hazard. Contact with electrically charged circuits could result in death or serious injury. Remove all rings, watches and other jewelry.

- 7 Close the hydraulic tank shutoff valve. Tag and disconnect and plug the hydraulic hose from the hydraulic tank shutoff valve.

**▲WARNING** Bodily injury hazard. Spraying hydraulic oil can penetrate and burn skin. Loosen hydraulic connections very slowly to allow the oil pressure to dissipate gradually. Do not allow oil to squirt or spray.

- 8 Open the valve on the hydraulic tank and drain the oil into a container of suitable capacity. Refer to Specifications., *Machine Specifications*.

**▲CAUTION** Bodily injury hazard. Beware of hot oil. Contact with hot oil may cause severe burns.



## Secondary Boom Components

- 9 Tag, disconnect and plug the hydraulic hose from the hydraulic tank return filter housing. Cap the fitting on the filter housing.

**⚠ WARNING** Bodily injury hazard. Spraying hydraulic oil can penetrate and burn skin. Loosen hydraulic connections very slowly to allow the oil pressure to dissipate gradually. Do not allow oil to squirt or spray.

**⚠ CAUTION** Bodily injury hazard. Beware of hot oil. Contact with hot oil may cause severe burns.

- 10 Remove the hydraulic tank mounting fasteners. Remove the hydraulic tank from the machine.
- 11 Open the ground controls side turntable cover.
- 12 Remove the terminal strip cover retaining fasteners. Remove the cover.
- 13 Remove the terminal strip retaining fasteners. Do not disconnect the wiring.
- 14 Remove the plastic plug in the bulkhead to access the secondary boom lift cylinder rod-end pivot pin.
- 15 Remove the mounting fasteners from the function manifold and slide the manifold to the side. This will allow access to the hydraulic tank side barrel-end pivot pin.

- 16 Attach a lifting strap from an overhead crane to the lug on the rod end of the secondary boom lift cylinder.

- 17 From the bottom side of the cylinder, remove the retaining fasteners from the secondary boom lift cylinder barrel-end pivot pins.

- 18 Remove the hose clamp under the lower secondary boom.

- 19 Use a slide hammer to remove both barrel-end pivot pins (access the pins from the access holes in the bulkheads, one on each side).

- 20 Remove the pin retaining fastener from the secondary boom lift cylinder rod-end pivot pin.

- 21 Use a soft metal drift to remove the secondary boom rod-end pivot pin.

**⚠ WARNING** Crushing hazard. The secondary boom lift cylinder may fall when the rod-end pivot pin is removed if not properly supported by the overhead crane.

- 22 Carefully lower the cylinder down through the secondary boom, enough to access the hydraulic hoses. Do not pinch the hoses.

**NOTICE** Component damage hazard. Hoses can be damaged if they are kinked or pinched.

---

## Secondary Boom Components

- 23 Tag, disconnect and plug the hydraulic hoses from the secondary boom lift cylinder. Cap the fittings on the cylinder.

**⚠ WARNING** Bodily injury hazard. Spraying hydraulic oil can penetrate and burn skin. Loosen hydraulic connections very slowly to allow the oil pressure to dissipate gradually. Do not allow oil to squirt or spray.

- 24 Remove the cylinder through the top of the secondary boom.

**⚠ WARNING** Crushing hazard. The secondary boom lift cylinder could become unbalanced and fall when removed from the machine if not properly attached to the overhead crane.

# Hydraulic Pump

## 6-1 Auxiliary and Function Pump

### How to Remove the Auxiliary Pump or Function Pump

Note: When removing a hose assembly or fitting, the O-ring (if equipped) on the fitting and/or hose end must be replaced. All connections must be torqued to specification during installation. Refer to Specifications, *Hydraulic Hose and Fitting Torque Specifications*.

- 1 Tag and disconnect the cables from the auxiliary pump.

**WARNING** Electrocutation/burn hazard. Contact with electrically charged circuits could result in death or serious injury. Remove all rings, watches and other jewelry.

- 2 Close the hydraulic shutoff valve located at the hydraulic tank.

**NOTICE** Component damage hazard. The engine must not be started with the hydraulic tank shut-off valves in the closed position or component damage will occur. If the tank valves are closed, remove the key from the key switch and tag the machine to inform personnel of the condition.

- 3 Tag, disconnect and plug the hydraulic hoses from the pump. Cap the fittings on the pump.

**WARNING** Bodily injury hazard. Spraying hydraulic oil can penetrate and burn skin. Loosen hydraulic connections very slowly to allow the oil pressure to dissipate gradually. Do not allow oil to squirt or spray.

- 4 Remove the pump mounting bolts from the pump. Carefully remove the pump from the electric motor.

**NOTICE** Component damage hazard. Be sure to open the two hydraulic tank valves and prime the pump after installing the pump.

# Manifolds

## 7-1 Function Manifold Components

The function manifold is located behind the ground controls turntable cover.

Index No.	Description	Schematic Item	Function	Torque
1	Solenoid valve, 3 position 4 way	A	Platform level up/down	20-25 ft-lbs / 27-34 Nm
2	Counterbalance valve	B	Platform level down	20-25 ft-lbs / 27-34 Nm
3	Counterbalance valve	C	Platform level up	20-25 ft-lbs / 27-34 Nm
4	Relief valve, 1100 psi / 75.8 bar	D	Turntable rotate left/right	30-35 ft-lbs / 41-47 Nm
5	Relief valve, 1600 psi / 110 bar	E	Secondary boom down	20-25 ft-lbs / 27-34 Nm
6	Relief valve, 1600 psi / 110 bar	F	Primary boom down	20-25 ft-lbs / 27-34 Nm
7	Relief Valve, 1800 psi / 124 bar (Z-30 N RJ)	G	Primary boom extend	20-25 ft-lbs / 27-34 Nm
8	Proportional solenoid valve	H	System flow regulating circuit	30-35 ft-lbs / 41-47 Nm
9	Check valve	I	Brake circuit	10-12 ft-lbs / 14-16 Nm
10	Solenoid valve, 3 position 4 way	J	Steer left/right	20-25 ft-lbs / 27-34 Nm
11	Solenoid valve, 3 position 4 way	K	Primary boom extend/retract	20-25 ft-lbs / 27-34 Nm
12	Pressure switch	L	Brake circuit	
13	Solenoid valve, N.C. poppet	M	Brake circuit	20-25 ft-lbs / 27-34 Nm
14	Orifice, 0.045 inch / 1.14 mm	N	Brake circuit	

# Manifolds

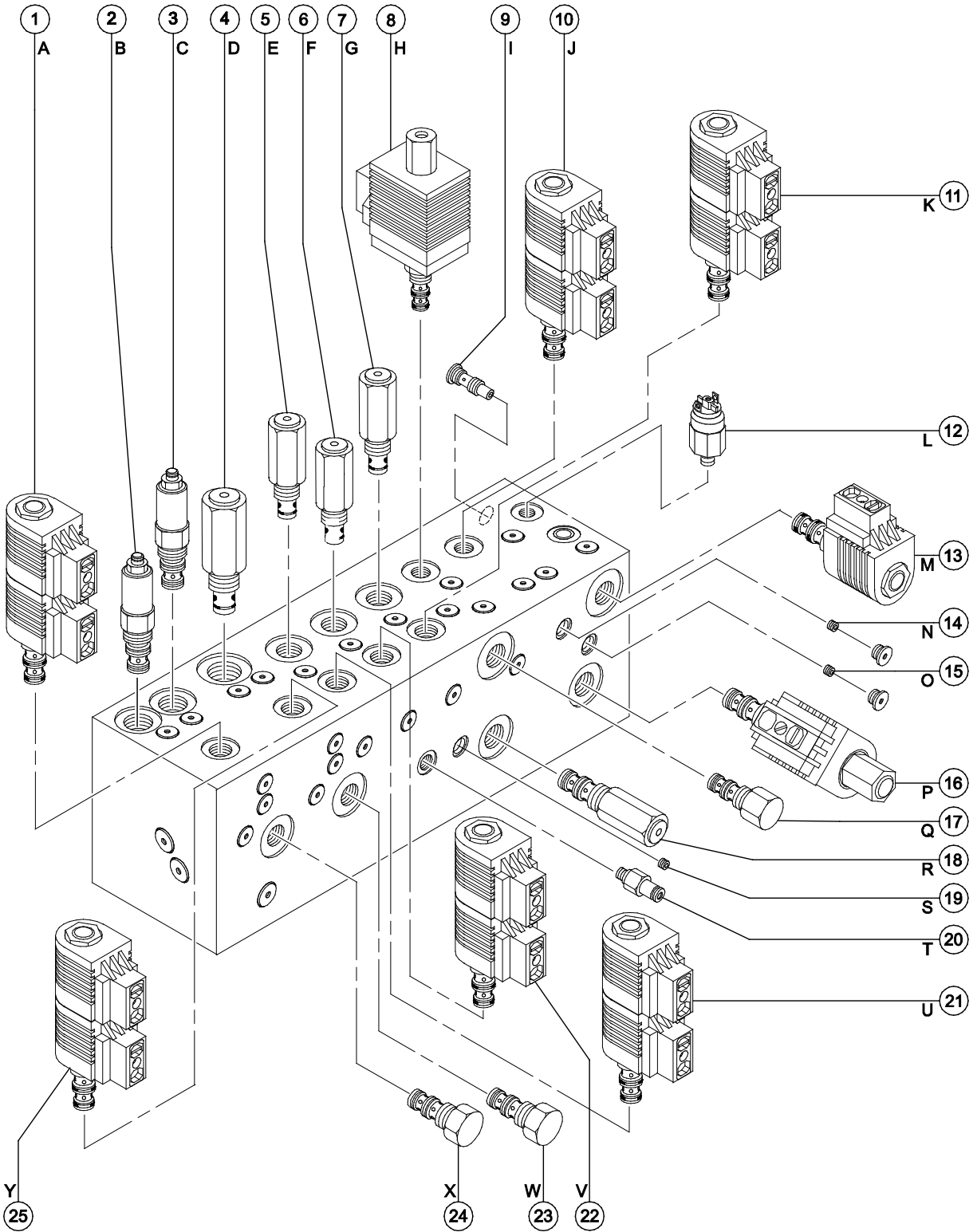

# Manifolds

## Function Manifold Components, continued

Index No.	Description	Schematic Item	Function	Torque
15	Orifice, 0.045 inch / 1.14 mm	O	Brake and steer circuit	
16	Solenoid valve, N.O. poppet	P	Brake circuit	20-25 ft-lbs / 27-34 Nm
17	Differential sensing valve	Q	Differential sensing circuit	30-35 ft-lbs / 41-47 Nm
18	Relief valve, 2800 psi / 193 bar (Z-30N and Z-30N RJ) 3200 psi / 221 bar (Z-34N and Z-34DC)	R	System relief	20-25 ft-lbs / 27-34 Nm
19	Orifice, 0.035 inch / 0.89 mm	S	Tank return circuit	
20	Diagnostic fitting	T	Testing	
21	Solenoid valve, 3 position 4 way	U	Secondary boom up/down	20-25 ft-lbs / 27-34 Nm
22	Solenoid valve, 3 position 4 way	V	Primary boom up/down	20-25 ft-lbs / 27-34 Nm
23	Flow regulator valve, 1.5 gpm / 5.7 L/min (before serial number 10808) Flow regulator valve, 1.8 gpm / 6.8 L/min (after serial number 10807)	W	Turntable rotate circuit	20-25 ft-lbs / 27-34 Nm
24	Flow regulator valve, 0.8 gpm / 3 L/min	X	Jib boom/platform rotate circuit	20-25 ft-lbs / 27-34 Nm
25	Solenoid valve, 3 position 4 way	Y	Turntable rotate left/right	20-25 ft-lbs / 27-34 Nm

# Manifolds

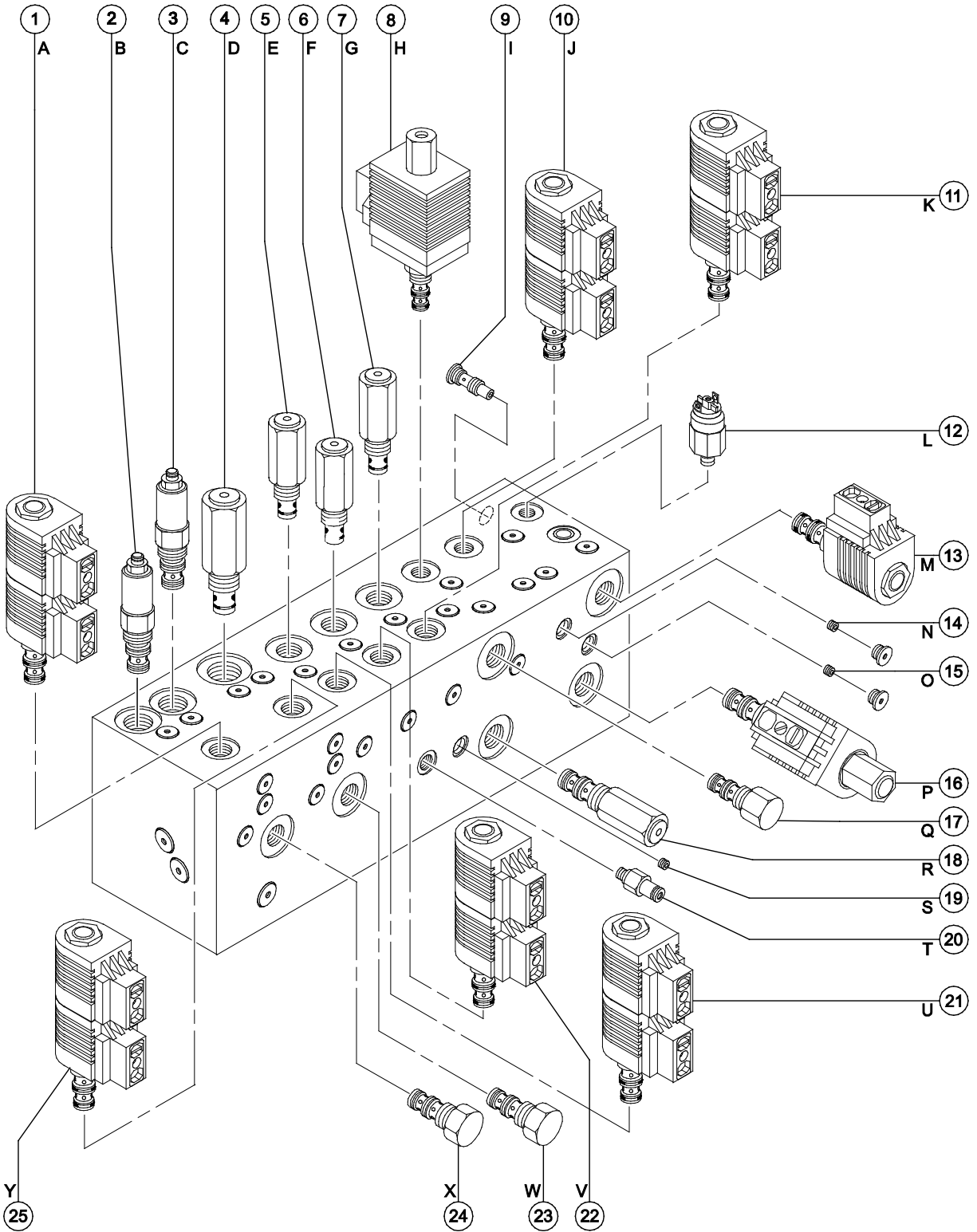

## Manifolds

### 7-2 Valve Adjustments - Function Manifold

#### How to Adjust the System Relief Valve

Note: Perform this procedure with the boom in the stowed position.

- 1 Connect a 0 to 5000 psi / 0 to 350 bar pressure gauge to the test port on the function manifold.
- 2 Turn the key switch to ground control and pull out the red Emergency Stop button to the on position.
- 3 Move and hold the function enable toggle switch to either side and move and hold the primary boom extend/retract toggle switch in the retract direction with the primary boom fully retracted. Observe the pressure reading on the pressure gauge. Refer to Specifications, *Manifold Component Specifications*.
- 4 Turn the machine off. Hold the system relief valve with a wrench and remove the cap (item R).
- 5 Adjust the internal hex socket. Turn it clockwise to increase the pressure or counterclockwise to decrease the pressure. Install the relief valve cap.

**⚠ WARNING** Tip-over hazard. Do not adjust the relief valve higher than specified.

- 6 Repeat steps 2 and 3 to confirm the relief valve pressure setting.
- 7 Remove the pressure gauge.

#### How to Adjust the Primary Boom Down Relief Valve

Note: Perform this procedure with the boom in the stowed position.

- 1 Connect a 0 to 3000 psi / 0 to 200 bar pressure gauge to the test port on the function manifold.
- 2 Turn the key switch to ground control and pull out the red Emergency Stop button to the on position.
- 3 Move and hold the function enable toggle switch to either side and move and hold the primary boom up/down toggle switch in the down direction with the primary boom fully lowered. Observe the pressure reading on the pressure gauge. Refer to Specifications, *Manifold Component Specifications*.
- 4 Turn the machine off. Hold the primary down relief valve with a wrench and remove the cap (item F).
- 5 Adjust the internal hex socket. Turn it clockwise to increase the pressure or counterclockwise to decrease the pressure. Then install the relief valve cap.

**⚠ WARNING** Tip-over hazard. Do not adjust the relief valve higher than specified.

- 6 Repeat steps 2 and 3 to confirm the relief valve pressure setting.
- 7 Remove the pressure gauge.



## Manifolds

### How to Adjust the Secondary Boom Down Relief Valve

Note: Perform this procedure with the boom in the stowed position.

- 1 Connect a 0 to 3000 psi / 0 to 200 bar pressure gauge to the test port on the function manifold.
- 2 Turn the key switch to ground control and pull out the red Emergency Stop button to the on position.
- 3 Move and hold the function enable toggle switch to either side and move and hold the secondary boom up/down toggle switch in the down direction with the secondary boom fully lowered. Observe the pressure reading on the pressure gauge. Refer to Specifications, *Manifold Component Specifications*.
- 4 Turn the machine off. Hold the secondary boom down relief valve with a wrench and remove the cap (item E).
- 5 Adjust the internal hex socket. Turn it clockwise to increase the pressure or counterclockwise to decrease the pressure. Then install the relief valve cap.

**⚠ WARNING** Tip-over hazard. Do not adjust the relief valve higher than specified.

- 6 Repeat steps 2 and 3 to confirm the relief valve pressure setting.
- 7 Remove the pressure gauge.

### How to Adjust the Primary Boom Extend Relief Valve

Note: Perform this procedure with the boom in the stowed position.

- 1 Connect a 0 to 3000 psi / 0 to 200 bar pressure gauge to the test port on the function manifold.
- 2 Turn the key switch to ground control and pull out the red Emergency Stop button to the on position.
- 3 Move and hold the function enable toggle switch to either side and move and hold the primary boom extend/retract toggle switch in the extend direction with the primary boom fully extended. Observe the pressure reading on the pressure gauge. Refer to Specifications, *Manifold Component Specifications*.
- 4 Turn the machine off. Hold the primary boom extend relief valve with a wrench and remove the cap (item G).
- 5 Adjust the internal hex socket. Turn it clockwise to increase the pressure or counterclockwise to decrease the pressure. Then install the relief valve cap.

**⚠ WARNING** Tip-over hazard. Do not adjust the relief valve higher than specified.

- 6 Repeat steps 2 and 3 to confirm the relief valve pressure setting.
- 7 Remove the pressure gauge.

---

## Manifolds

### How to Adjust the Turntable Rotate Relief Valve

Note: Perform this procedure with the boom in the stowed position.

- 1 Connect a 0 to 3000 psi / 0 to 200 bar pressure gauge to the test port on the function manifold.
- 2 Turn the key switch to ground control and pull out the red Emergency Stop button to the on position.
- 3 Move and hold the function enable toggle switch to either side and move and hold the turntable rotate toggle switch in the right direction (until turntable stops against the rotation stop). Observe the pressure reading on the pressure gauge. Refer to Specifications, *Manifold Component Specifications*.
- 4 Turn the machine off. Hold the turntable relief valve(s) with a wrench and remove the cap (item D).
- 5 Adjust the internal hex socket. Turn it clockwise to increase the pressure or counterclockwise to decrease the pressure. Then install the relief valve cap.

**⚠ WARNING** Tip-over hazard. Do not adjust the relief valve higher than specified.

- 6 Repeat steps 2 and 3 to confirm the relief valve pressure setting.
- 7 Remove the pressure gauge.

# Manifolds

## 7-3

### Jib Boom and Platform / Jib Boom Rotate Manifold Components (before serial numbers Z30N10-12102, Z30N10 (RJ)-12197, Z34N10-8838 and Z3410-7720)

The jib boom/platform rotate manifold is mounted to the jib boom.

Index No.	Description	Schematic Item	Function	Torque
1	Solenoid valve, 3 position 4 way	AA	Jib boom up/down	20-25 ft-lbs / 27-34 Nm
2	Solenoid valve, 3 position 4 way	AB	Platform rotate left/right	20-25 ft-lbs / 27-34 Nm
3	Solenoid valve, 3 position 4 way	AC	Jib boom rotate left/right	20-25 ft-lbs / 27-34 Nm
4	Flow regulator valve, 0.3 gpm / 1.14 L/min	AD	Platform rotate circuit	20-25 ft-lbs / 27-34 Nm
5	Orifice plug, 0.025 inch / 0.64 mm (located under plug)	AE	Jib boom rotate circuit	

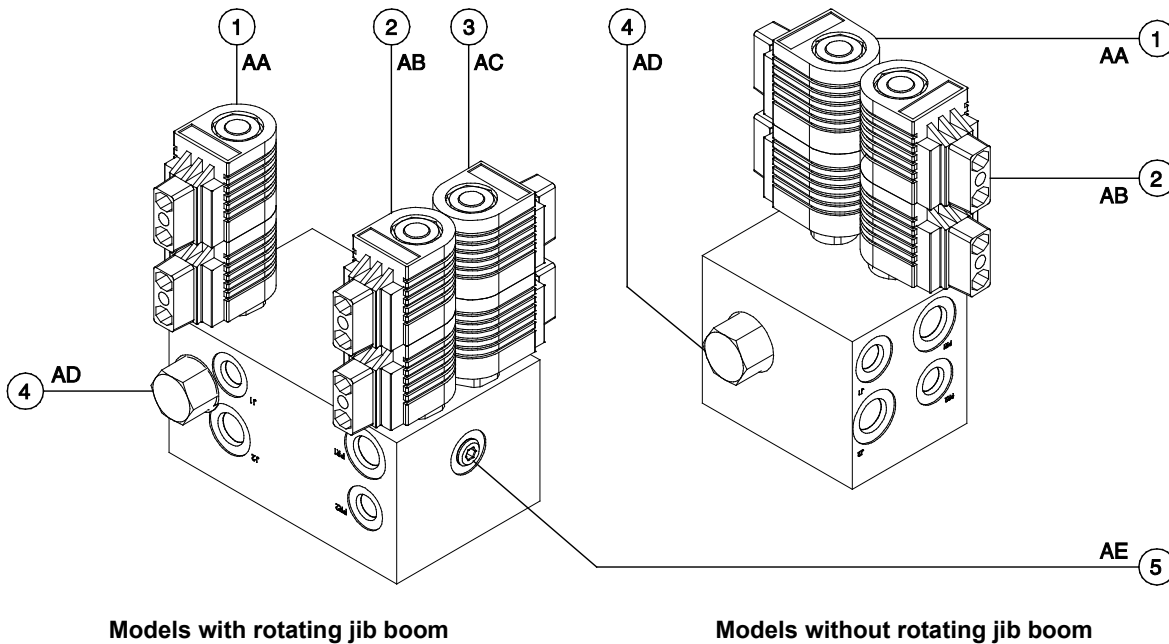

# Manifolds

## Jib Boom and Platform / Jib Boom Rotate Manifold Components (from serial numbers Z30N10-12102, Z30N10 (RJ)-12197, Z34N10-8838 and Z3410-7720)

The jib boom/platform rotate manifold is mounted to the jib boom.

Index No.	Description	Schematic Item	Function	Torque
1	Solenoid valve, 3 position 4 way	AA	Jib boom up/down	20-25 ft-lbs / 27-34 Nm
2	Solenoid valve, 3 position 4 way	AB	Platform rotate left/right	20-25 ft-lbs / 27-34 Nm
3	Solenoid valve, 3 position 4 way	AC	Jib boom rotate left/right	20-25 ft-lbs / 27-34 Nm
4	Flow regulator valve, 0.3 gpm / 1.14 L/min	AD	Platform rotate circuit	20-25 ft-lbs / 27-34 Nm
5	Orifice plug, 0.025 inch / 0.64 mm (located under plug)	AE	Jib boom rotate circuit	

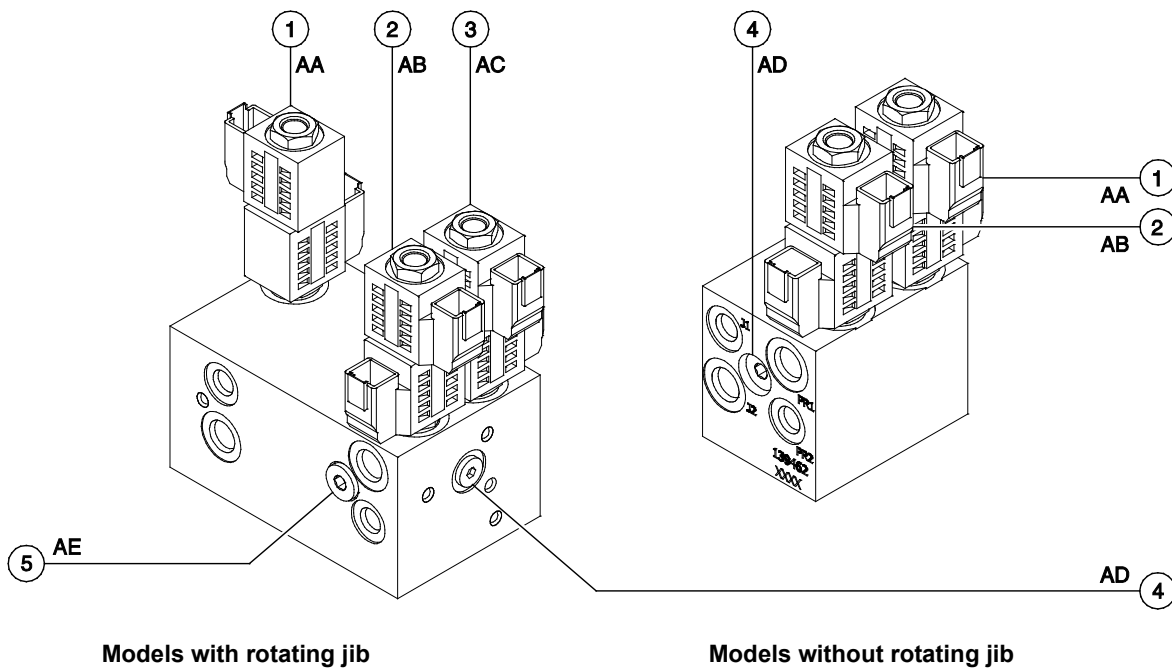

# Manifolds

## 7-4 Valve Coils

### How to Test a Coil

A properly functioning coil provides an electromotive force which operates the solenoid valve. Critical to normal operation is continuity within the coil that provides this force field.

**⚠ WARNING** Electrocutation/burn hazard. Contact with electrically charged circuits could result in death or serious injury. Remove all rings, watches and other jewelry.

- 1 Tag and disconnect the wiring from the coil to be tested.
- 2 Test the coil resistance.

**Coils with 2 terminals:** Connect the leads from the ohmmeter to the valve coil terminals.

**Coils with 1 terminal:** Connect the positive lead from the ohmmeter to the valve coil terminal, then connect the negative lead from the ohmmeter to the internal ring of the valve coil.

- ⊙ Result: The resistance should be within specification, plus or minus 30%.
- ⊗ Result: If the resistance is not within specification, plus or minus 30%, replace the coil.

## Valve Coil Resistance Specification

Note: The following coil resistance specifications are at an ambient temperature of 68°F / 20°C. As valve coil resistance is sensitive to changes in air temperature, the coil resistance will typically increase or decrease by 4% for each 18°F / 10°C that your air temperature increases or decreases from 68°F / 20°C.

### Valve Coil Resistance Specification

Description	Specification
Solenoid valve, 3 position 4 way, 20V DC (schematic items A, J, K, U, V, Y, AA, BB and CC)	22 Ω
Proportional solenoid valve, 24V DC (schematic item H)	19.5 Ω
Solenoid valve, N.C. poppet, 20V DC (schematic item M)	23.5 Ω
Solenoid valve, N.O. poppet, 20V DC (schematic item P)	23.5 Ω

## Manifolds

### How to Test a Coil Diode

Properly functioning coil diodes protect the electrical circuit by suppressing voltage spikes. Voltage spikes naturally occur within a function circuit following the interruption of electrical current to a coil. Faulty diodes can fail to protect the electrical system, resulting in a tripped circuit breaker or component damage.

**⚠ WARNING** Electrocution/burn hazard. Contact with electrically charged circuits could result in death or serious injury. Remove all rings, watches and other jewelry.

- 1 Test the coil for resistance. See, How to Test a Coil.
- 2 Connect a 10Ω resistor to the negative terminal of a known good 9V DC battery. Connect the other end of the resistor to a terminal on the coil.

---

#### Resistor, 10Ω

---

Genie part number 27287

---

Note: The battery should read 9V DC or more when measured across the terminals.

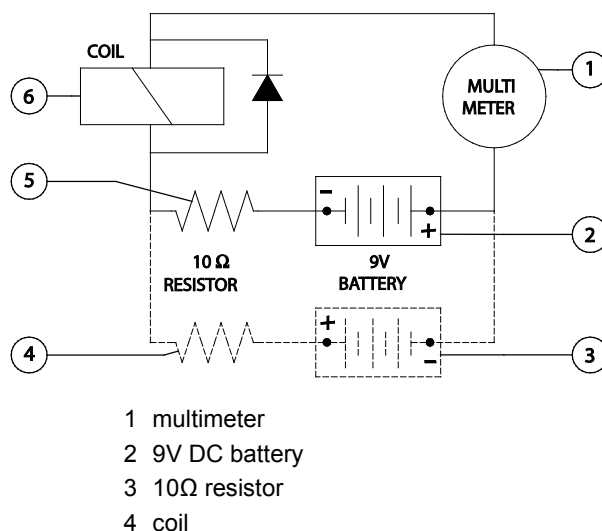

Note: Dotted lines in illustration indicate a reversed connection as specified in step 6

- 3 Set a multimeter to read DC current.

Note: The multimeter, when set to read DC current, should be capable of reading up to 800 mA.

- 4 Connect the negative lead to the other terminal on the coil.
- 5 Momentarily connect the positive lead from the multimeter to the positive terminal on the 9V DC battery. Note and record the current reading.

---

## Manifolds

- 6 At the battery or coil terminals, reverse the connections. Note and record the current reading.
  - ⦿ Result: Both current readings are greater than 0 mA and are different by a minimum of 20%. The coil is good.
  - ⊗ Result: If one or both of the current readings are 0 mA, or if the two current readings do not differ by a minimum of 20%, the coil and/or its internal diode are faulty and the coil should be replaced.

---

# Turntable Rotation Components

## 8-1

### Turntable Rotation Hydraulic Motor

---

The turntable rotation hydraulic motor is the only serviceable component of the turntable rotation assembly. The worm gear must not be removed from the housing. In order to remove the housing, the turntable has to be removed.

### How to Remove the Turntable Rotation Motor

Note: When removing a hose assembly or fitting, the O-ring (if equipped) on the fitting and/or hose end must be replaced. All connections must be torqued to specification during installation. Refer to Specifications, *Hydraulic Hose and Fitting Torque Specifications*.

- 1 Tag, disconnect and plug the hydraulic hoses from the turntable rotation motor. Cap the fittings on the motor.

**⚠ WARNING**

Bodily injury hazard. Spraying hydraulic oil can penetrate and burn skin. Loosen hydraulic connections very slowly to allow the oil pressure to dissipate gradually. Do not allow oil to squirt or spray.

- 2 Remove the turntable rotation motor mounting bolts. Remove the motor from the machine.



## Steer Axle Components

### 9-1 Hub and Bearings, 2WD Models

#### How to Remove the Hub and Bearings

- 1 Loosen the wheel lug nuts. Do not remove them.
- 2 Block the non-steer wheels and place a lifting jack under the steer axle.
- 3 Raise the machine. Place blocks under the drive chassis for support.
- 4 Remove the lug nuts. Remove the tire and wheel assembly.
- 5 Remove the dust cap, cotter pin and castle nut.

Note: Always use a new cotter pin when installing a castle nut.

- 6 Pull the hub off the yoke spindle. The washer and outer bearing should fall loose from the hub.
- 7 Place the hub on a flat surface and gently pry the grease seal out of the hub. Remove the inner bearing.

Note: When removing a bearing, always use a new inner bearing seal.

#### How to Install the Hub and Bearings

Note: When replacing a wheel bearing, both the inner and outer bearings, including the pressed-in races, must be replaced.

- 1 Be sure that both bearings are packed with clean, fresh grease.
- 2 Place the large inner bearing into the rear of the hub.
- 3 Install a new bearing grease seal into the hub by pressing it evenly into the hub until it is flush.

Note: Always replace the bearing grease seal when removing the hub.

- 4 Slide the hub onto the yoke spindle.

**NOTICE** Component damage hazard. Do not apply excessive force or damage to the lip of the seal may occur.

- 5 Fill the hub cavity with clean, fresh grease.
- 6 Place the outer bearing into the hub.
- 7 Install the washer and castle nut.
- 8 Tighten the castle nut to 158 ft-lbs / 214 Nm to seat the bearings.

Note: Rotate the hub by hand while torquing the castle nut to make sure the bearings seat properly.

---

## Steer Axle Components

- 9 Loosen the castle nut one full turn and then torque to 35 ft-lbs / 47 Nm.
- 10 Install a new cotter pin. Bend the cotter pin to lock it in place.

Note: Always use a new cotter pin when installing a castle nut.

- 11 Install the dust cap, then the tire and wheel assembly.
- 12 Lower the machine and remove the blocks.
- 13 Torque the wheel lug nuts to specification. Refer to Specifications, *Machine Torque Specifications*.

## Non-steer Axle Components

### 10-1 Motor Controller

The drive motor controller is located under the non-steer end drive chassis cover. The drive motor controller can recognize machine drive malfunctions and display controller fault codes by flashing a LED at the ground controls and on the motor controller. See the Fault Code section of this manual for a list of fault codes and additional information. There are no adjustments needed on the drive joystick controller. For further information or assistance, consult the Genie Industries Service Department.

### How to Test the Motor Controller

Note: Use the following procedure to test the motor controller. If the motor controller is found to be faulty, note which test failed and which fault code (if any) was present at the time of failure.

- 1 Turn the key switch to the off position and disconnect the battery packs from the machine.
- 2 Tag and disconnect all power cables from the motor controller.

**⚠ WARNING** Electrocution/burn hazard. Contact with electrically charged circuits could result in death or serious injury. Remove all rings, watches and other jewelry.

- 3 Press the release tab on the motor controller harness connector and remove the motor controller harness connector from the motor controller.

- 4 Set an ohmmeter to diode test mode.
- 5 Connect the leads from an ohmmeter to test each motor controller terminal combination listed below and check the forward / reverse bias (diode test).
  - ⊙ Result: All desired results must be within the specified range. If any test has a result not within the specified range, replace the motor controller.

#### Forward Bias:

Test		Desired result
Positive Lead	Negative Lead	
M-	B+	0.4 to 0.45
B-	M-	0.4 to 0.45
F1	B+	0.45 to 0.5
F2	B+	0.45 to 0.5
B-	F1	0.45 to 0.5
B-	F2	0.45 to 0.5

#### Reverse Bias:

Test		Desired result
Positive Lead	Negative Lead	
B+	M-	Rises to .0L V
M-	B-	Rises to .0L V
B+	F1	Rises to .0L V
B+	F2	Rises to .0L V
F1	B-	Rises to .0L V
F2	B-	Rises to .0L V

## Fault Codes



### Observe and Obey:

- ☑ Troubleshooting and repair procedures shall be completed by a person trained and qualified on the repair of this machine
- ☑ Immediately tag and remove from service a damaged or malfunctioning machine.
- ☑ Repair any machine damage or malfunction before operating the machine.
- ☑ Unless otherwise specified, perform each procedure with the machine in the following configuration:
  - Machine parked on a firm, level surface
  - Key switch in the off position with the key removed
  - The red Emergency Stop button in the off position at both ground and platform controls
  - Wheels chocked
  - All external AC power supply disconnected from the machine
  - Boom in the stowed position
  - Turntable secured with the turntable rotation lock
  - Welder disconnected from the machine (if equipped with the weld cable to platform option)

### Before Troubleshooting:

- ☑ Read, understand and obey the safety rules and operating instructions in the appropriate operator's manual on your machine.
- ☑ Be sure that all necessary tools and test equipment are available and ready for use.
- ☑ Read each appropriate fault code thoroughly. Attempting short cuts may produce hazardous conditions.
- ☑ Be aware of the following hazards and follow generally accepted safe workshop practices.

#### **⚠ WARNING**

Electrocution/burn hazard. Contact with electrically charged circuits could result in death or serious injury. Remove all rings, watches and other jewelry.

Note: Two persons will be required to safely perform some troubleshooting procedures.

## Fault Codes

### Fault Codes

#### **⚠ DANGER**

Tip-over hazard. When adjusting the raised drive speed settings, the maximum raised drive speed must not exceed 0.6 mph / 1Km/h or 40 feet / 45 seconds / 12.2 meters / 45 seconds. If the machine is allowed to drive faster than specification, the machine could become unstable and will tip over.

Note: Additional troubleshooting of the fault codes may be accomplished by using the hand-held pendant motor controller programmer (Genie part number 128551).

Note: When using the hand-held pendant motor controller programmer, the M1 MAX SPEED needs to be set to 33. If needed, adjust the M1 MAX SPEED higher or lower to achieve the maximum raised drive speed of 0.6 mph / 1Km/h or 40 feet / 45 seconds / 12.2 meters / 45 seconds.

The controller status indicator light will flash a fault code to aid in troubleshooting. This indicator light is mounted on the tilt level sensor mounting bracket, located behind the cover on the ground controls side.

Fault codes are two digits. The controller status indicator light will blink the first digit of a two digit code, pause for 1 second, and then blink the second digit. There will be a 2 second pause between codes.

For example: the indicator light blinks 4 consecutive times, pauses for 1 second, and then blinks 1 time. That would indicate Fault Code 41.

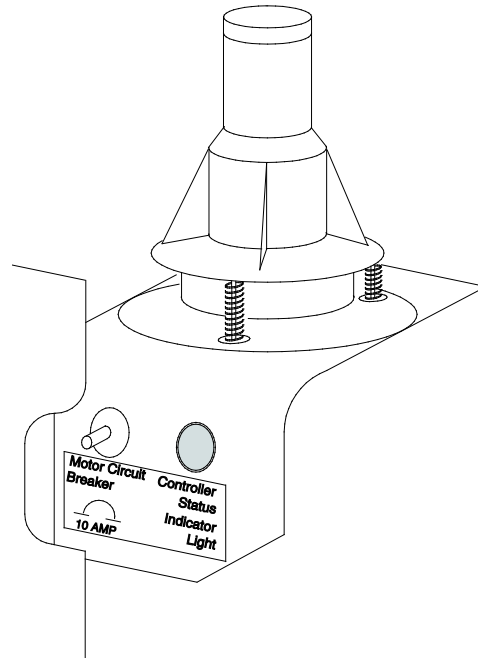

## Fault Codes

### Fault Code Chart

Fault Code	Programmer Diagnostic Display	Condition	Possible Causes	Solution
Fault code LED is off or is on, but not blinking	COMMUNICATION ERROR	Machine will not drive.	The key switch or Emergency Stop button(s) was cycled on and off faster than 5 seconds OR controller sensed an internal error during start up.	Push in the ground control red Emergency Stop button to the off position and wait for 5 seconds. Pull out the ground control red Emergency Stop button to the on position. If problem persists, replace the motor controller.
1		Normal operation.		
12	HW FAILSAFE 1-2-3	Machine will not drive.	The motor controller failed self test.	Replace the motor controller.
13	M- SHORTED	Machine will not drive.	The motor controller has a internal short between M- and B-terminals.	Test the motor controller. See Repair Section.
	FIELD OPEN	Machine will not drive.	Motor wiring is loose OR motor is defective OR motor controller has an internal short.	Check for loose or open connections at the drive motors and motor controller OR replace the defective drive motor OR test the motor controller. See Repair Section.
	ARM SENSOR	Machine will not drive.	Defective motor controller.	Replace the motor controller.
	FLD SENSOR	Machine will not drive.	Defective motor controller.	Replace the motor controller.

## Fault Codes

### Fault Code Chart

Fault Code	Programmer Diagnostic Display	Condition	Possible Causes	Solution
21	THROTTLE FAULT 1	Machine will not drive.	Open in wht/red wire #32 at pin 14 or red/wht wire #29 at pin 16 on the motor controller going from drive joystick to pins 14 and 16 at the motor controller OR pin 14 is internally shorted to power or ground OR the potentiometer on the drive joystick is defective.	Consult Genie Product Support.
	THROTTLE FAULT 2	Machine will not drive.	Pin 14 (wht/red #32) is shorted to power or ground OR the potentiometer on the drive joystick is defective.	Consult Genie Product Support.
31	CONT DRVR OC	Machine will not drive.	Main contactor (PR1) coil defective OR brake release relay CR5 defective.	Replace main contactor PR1 or brake release relay CR5 OR replace the motor controller.
32	MAIN CONT WELDED	Machine will not drive.	Main contactor (PR1) contacts stuck closed OR grn wire at pin 17 on motor controller shorted to ground OR open in motor armature wiring OR motor controller has an internal short to ground.	Consult Genie Product Support.
33	PRECHARGE FAULT	Machine will not drive.	External short between B+ terminal on motor controller and ground OR motor controller is defective.	Repair short between B+ terminal on motor controller and ground OR replace motor controller.  Note: Short can be on any part of circuit connected to the B+ terminal on the motor controller.

## Fault Codes

### Fault Code Chart

Fault Code	Programmer Diagnostic Display	Condition	Possible Causes	Solution
34	MISSING CONTACTOR	Machine will not drive.	Motor controller does not detect the main contactor PR1 or brake release relay CR5.	Consult Genie Product Support.
	MAIN CONT DNC	Machine will not drive.	Main contactor PR1 or brake release relay CR5 did not close OR open in org/red wire to PR1 and/or CR5 OR main contactor and/or brake release relay is defective.	Consult Genie Product Support.
41	LOW BATTERY	Machine will not drive.	Battery supply voltage to motor controller less than 32V DC.	Completely charge batteries OR check battery cable condition OR check for corrosion or loose connections at battery terminals and motor controller.
42	OVERVOLTAGE	Machine will not drive.	Battery supply voltage to motor controller more than 55V DC OR machine is being operated with the battery charger plugged in.	Be sure the battery charger is disconnected OR check for loose battery cables or poor connections.
43	THERMAL CUTBACK	Machine will not drive.	Machine being operated outside of temperature range of -13°F to 185°F / -25°C to 85°C OR machine being driven under excessive load OR motor controller is not being cooled sufficiently.	Operate machine within specified temperature limits OR check for debris around motor controller preventing proper cooling of the controller OR check for mechanical restrictions causing excessive load on the machine.



## Schematics



### Observe and Obey:

- Troubleshooting and repair procedures shall be completed by a person trained and qualified on the repair of this machine
- Immediately tag and remove from service a damaged or malfunctioning machine.
- Repair any machine damage or malfunction before operating the machine.

### Before Troubleshooting:

- Read, understand and obey the safety rules and operating instructions in the appropriate operator's manual on your machine.
- Be sure that all necessary tools and test equipment are available and ready for use.

### About This Section

There are two groups of schematics in this section.

#### Electrical Schematics

**⚠ WARNING**

Electrocution/burn hazard. Contact with electrically charged circuits could result in death or serious injury. Remove all rings, watches and other jewelry.

#### Hydraulic Schematics











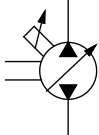

**⚠ WARNING**

Bodily injury hazard. Spraying hydraulic oil can penetrate and burn skin. Loosen hydraulic connections very slowly to allow the oil pressure to dissipate gradually. Do not allow oil to squirt or spray.

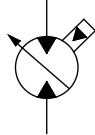
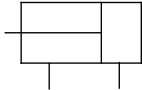
# Electrical Symbol Legend

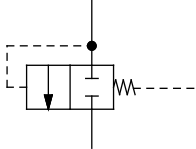
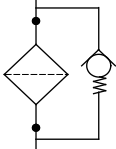
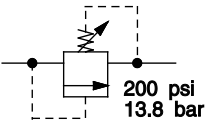
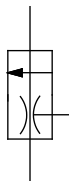
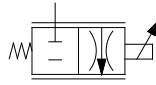
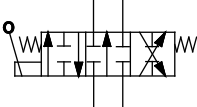
Battery	Coil, solenoid or relay	Horn or alarm	Flashing beacon	Gauge
Diode	Hour meter	LED	Fuse with amperage	Foot switch
T-circuits connect	Limit Switch	Power relay	Coil with suppression	Fuel or RPM solenoid
Connection - no terminal	T-circuits connect at terminal	Circuits crossing - no connection	Quick disconnect terminal	Circuit breaker with amperage
Key switch	Toggle switch DPDT	Toggle switch SPDT	Pump or Motor	Tilt sensor
Horn button - normally open	Emergency stop button - normally closed	Resistor with ohm value	Battery separator	Gauge sending unit
Oil temperature switch normally open	Coolant temperature switch - normally open	Oil pressure switch normally closed	Control relay contact normally open	Diode starting aid, glow plug or flame ignitor

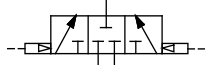
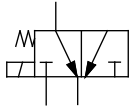
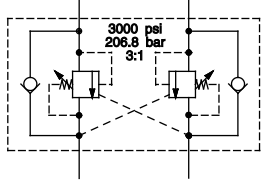
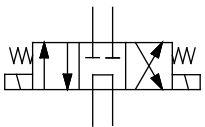
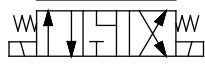
# Hydraulic Symbols Legend

 <p>0.037 inch 0.94 mm</p> <p>Orifice with size</p>	 <p>Check valve</p>	 <p>Shut off valve</p>	 <p>Brake</p>
 <p>Pump, fixed displacement</p>	 <p>Pump, bi-directional variable displacement</p>	 <p>Motor, bi-directional</p>	 <p>Motor, 2 speed bi-directional</p>
 <p>Double acting cylinder</p>	 <p>Pump, prime mover (engine or motor)</p>	 <p>Shuttle valve, 2 position, 3 way</p>	 <p>Differential sensing valve</p>
 <p>Filter with bypass relief valve</p>	 <p>200 psi 13.8 bar</p> <p>Relief valve with pressure setting</p>	 <p>Priority flow regulator valve</p>	 <p>Solenoid operated proportional valve</p>
 <p>Directional valve (mechanically activated)</p>	 <p>50% 50%</p> <p>Flow divider/combiner valve</p>	 <p>Pilot operated 3 position, 3 way shuttle valve</p>	 <p>Solenoid operated 2 position, 3 way directional valve</p>
 <p>3000 psi 206.8 bar 3:1</p> <p>Counterbalance valve with pressure and pilot ratio</p>	 <p>Solenoid operated 3 position, 4 way directional valve</p>	 <p>Solenoid operated 3 position, 4 way proportional directional valve</p>	 <p>2 position, 2 way solenoid valve</p>

# Limit Switch Location Legend

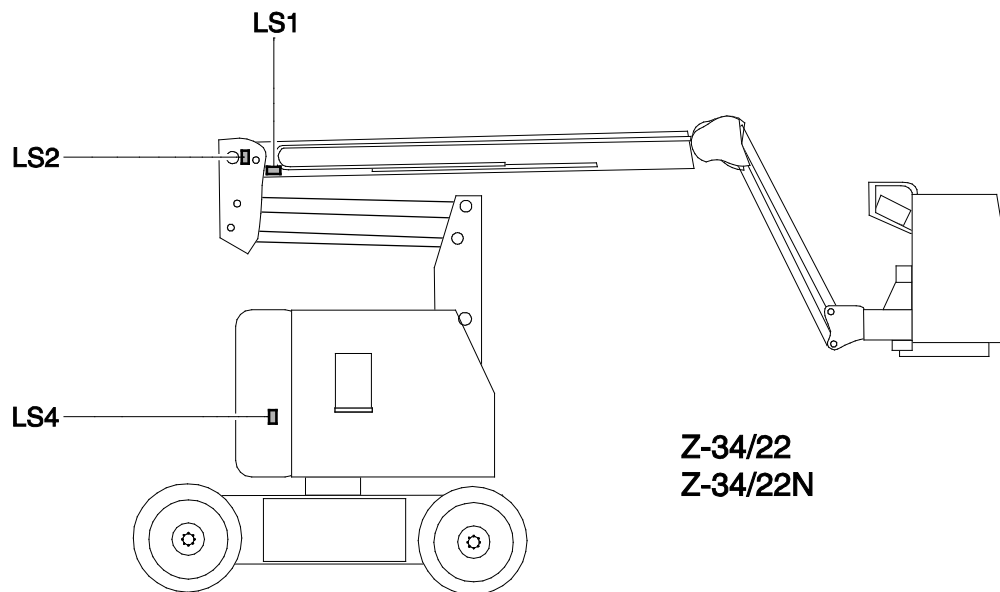
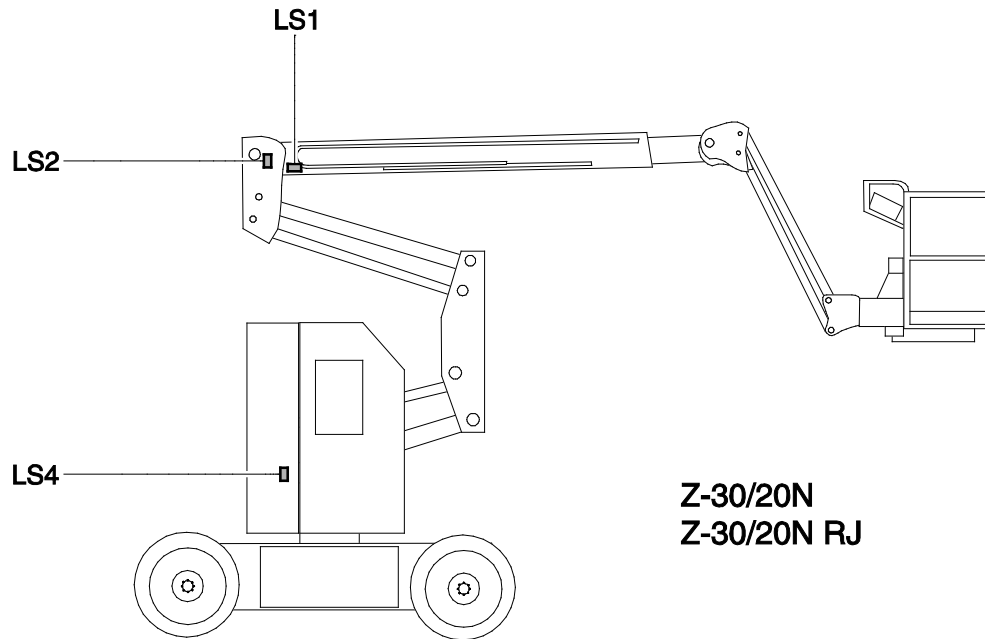

---

## Power Cable Wiring Diagram

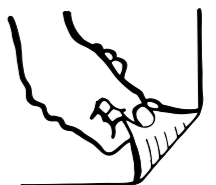

### Power Cable Wiring Diagram

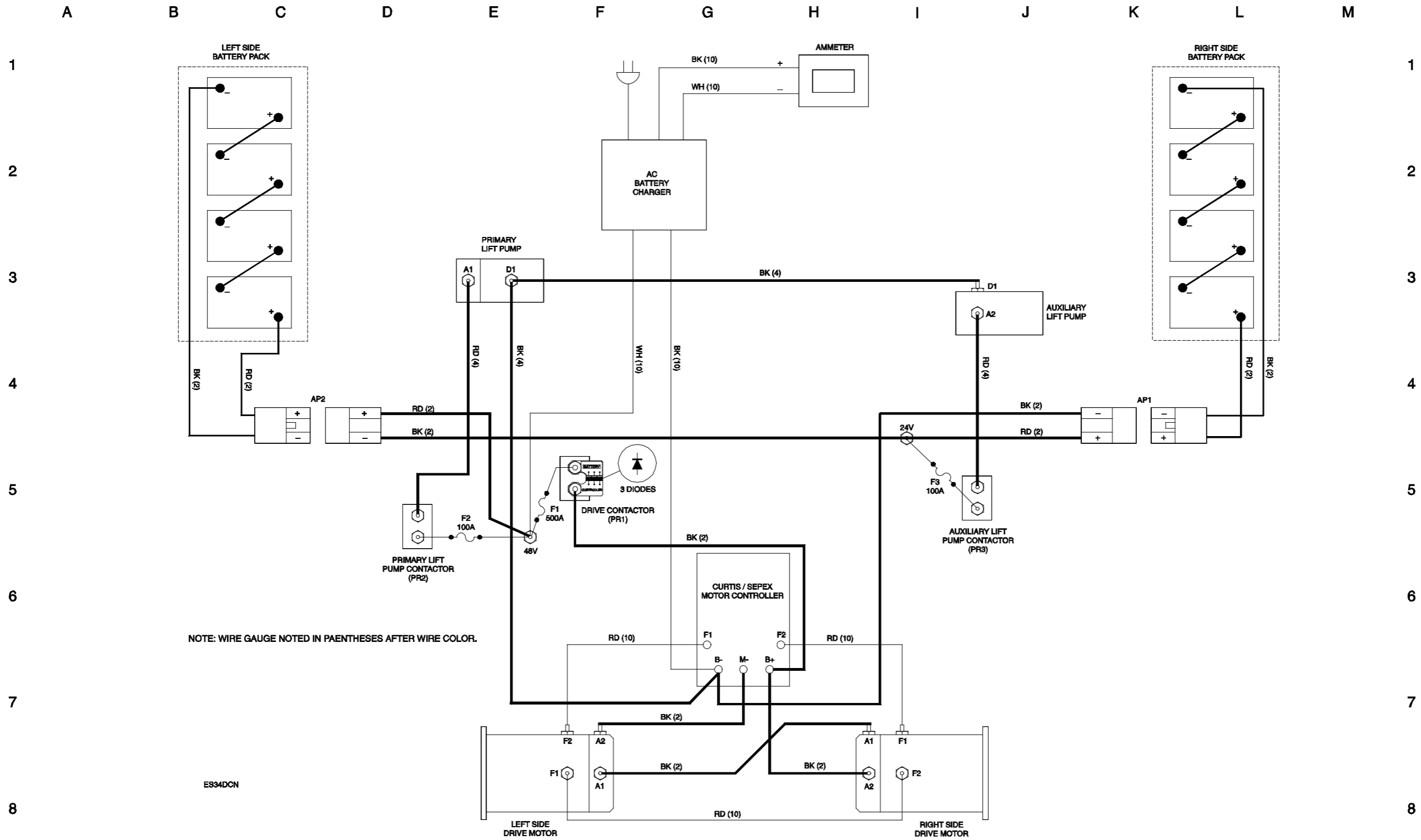

# Drive Contactor Panel Wiring Diagram

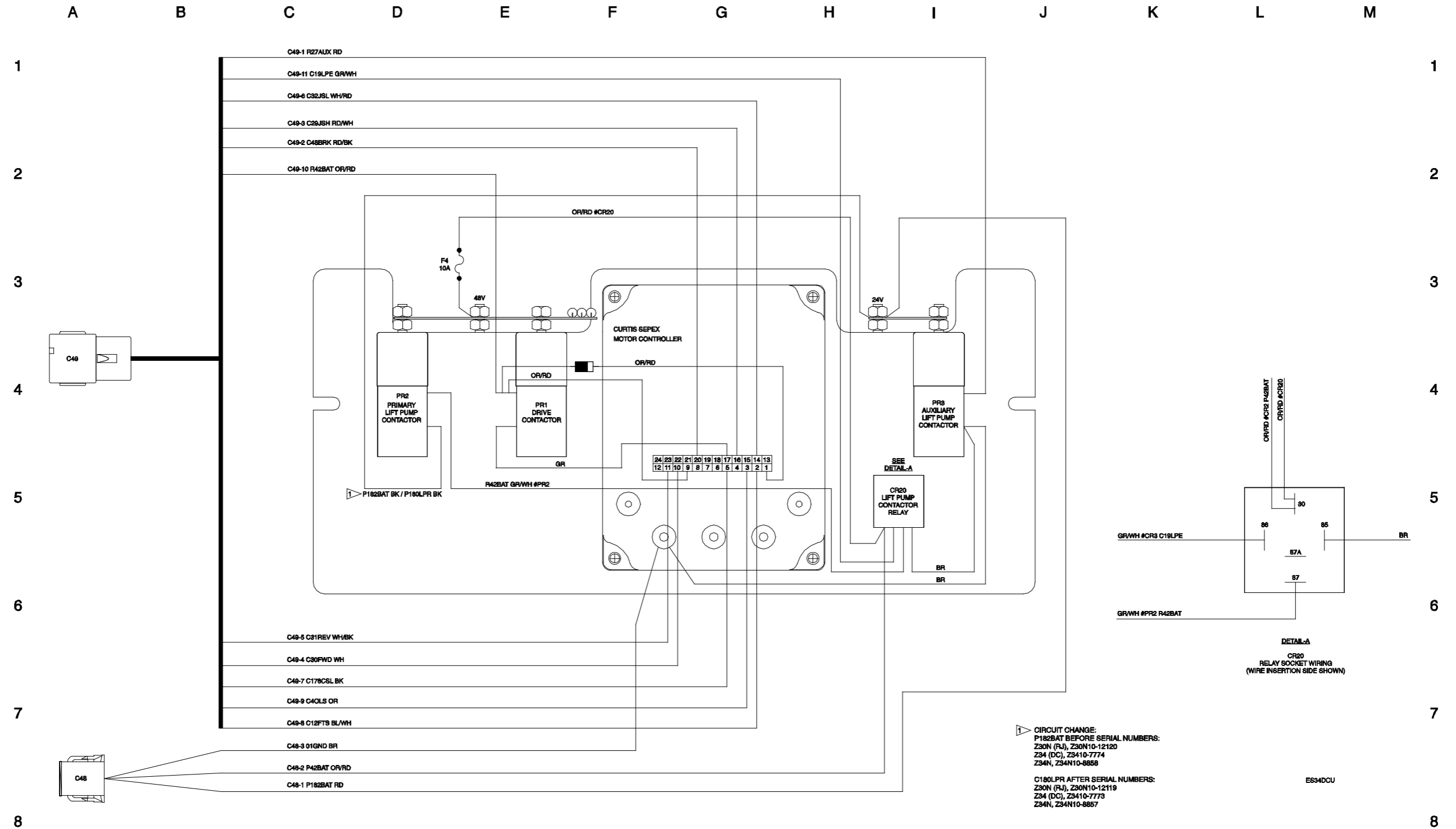

## Drive Contactor Panel Wiring Diagram

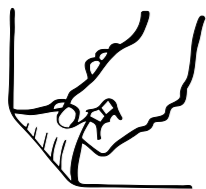



---

## Manifold and Limit Switch Wiring Diagram

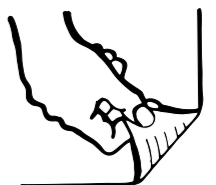

# Manifold and Limit Switch Wiring Diagram

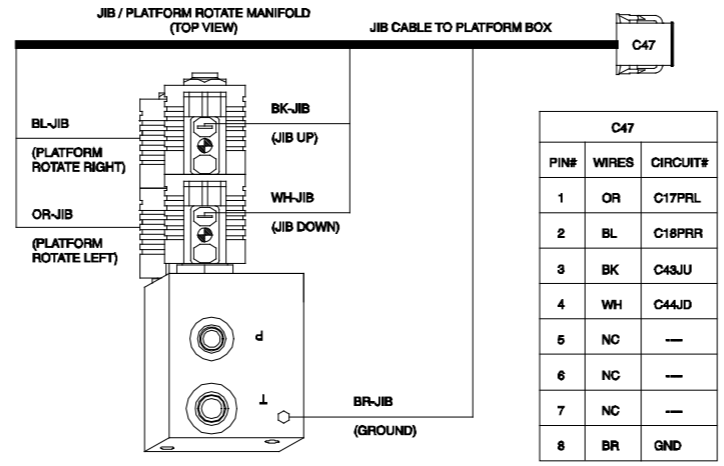
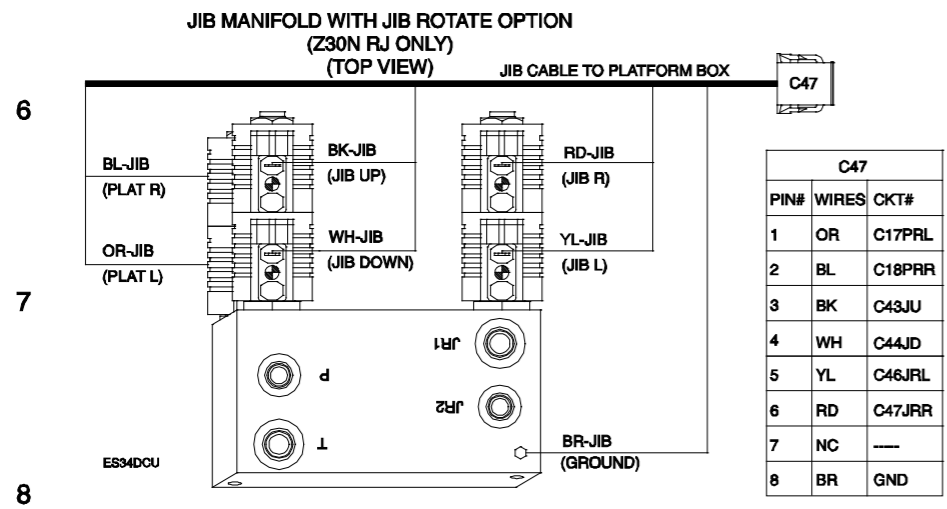
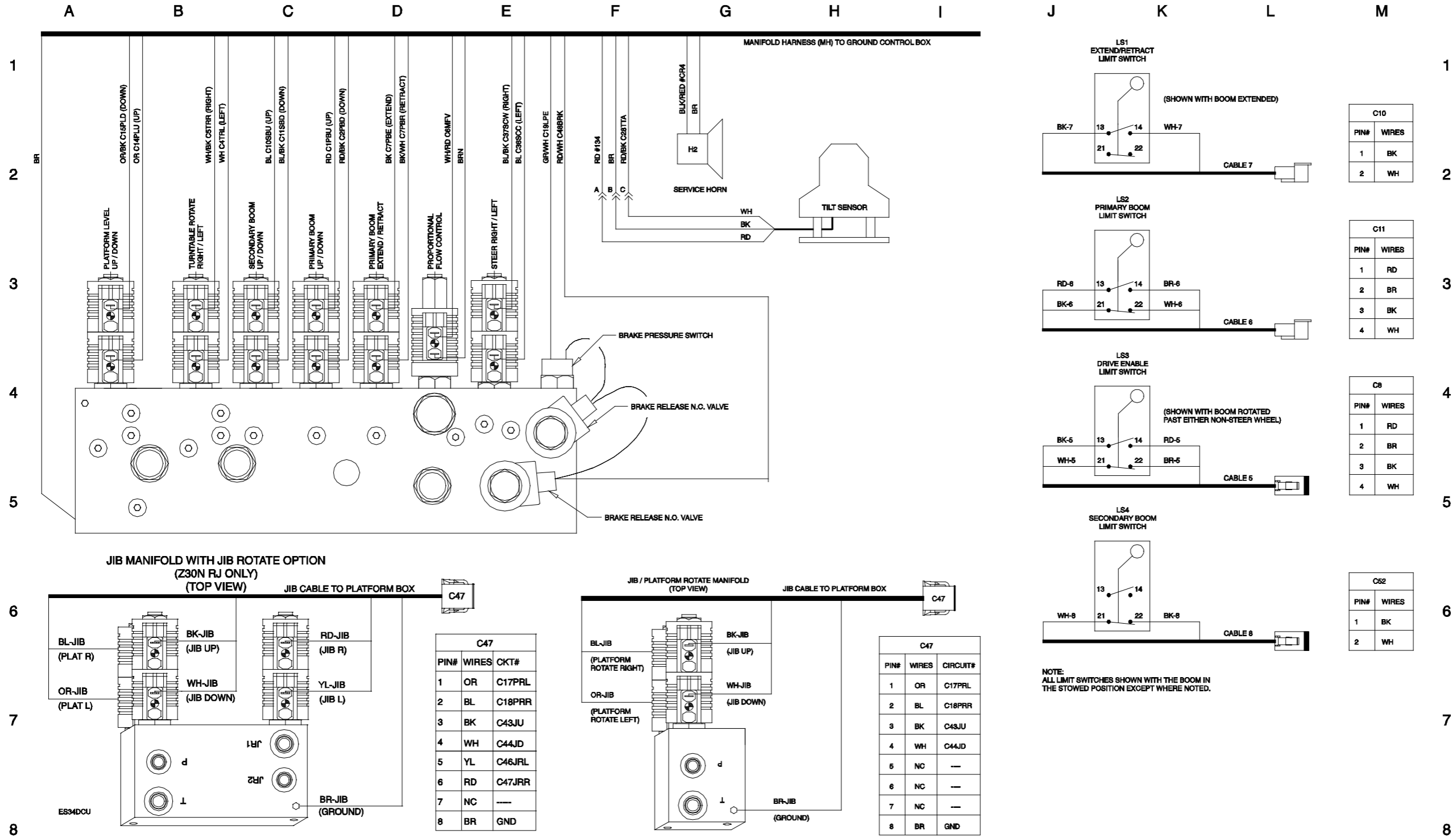

### LVI/BCI Option Wiring Diagram

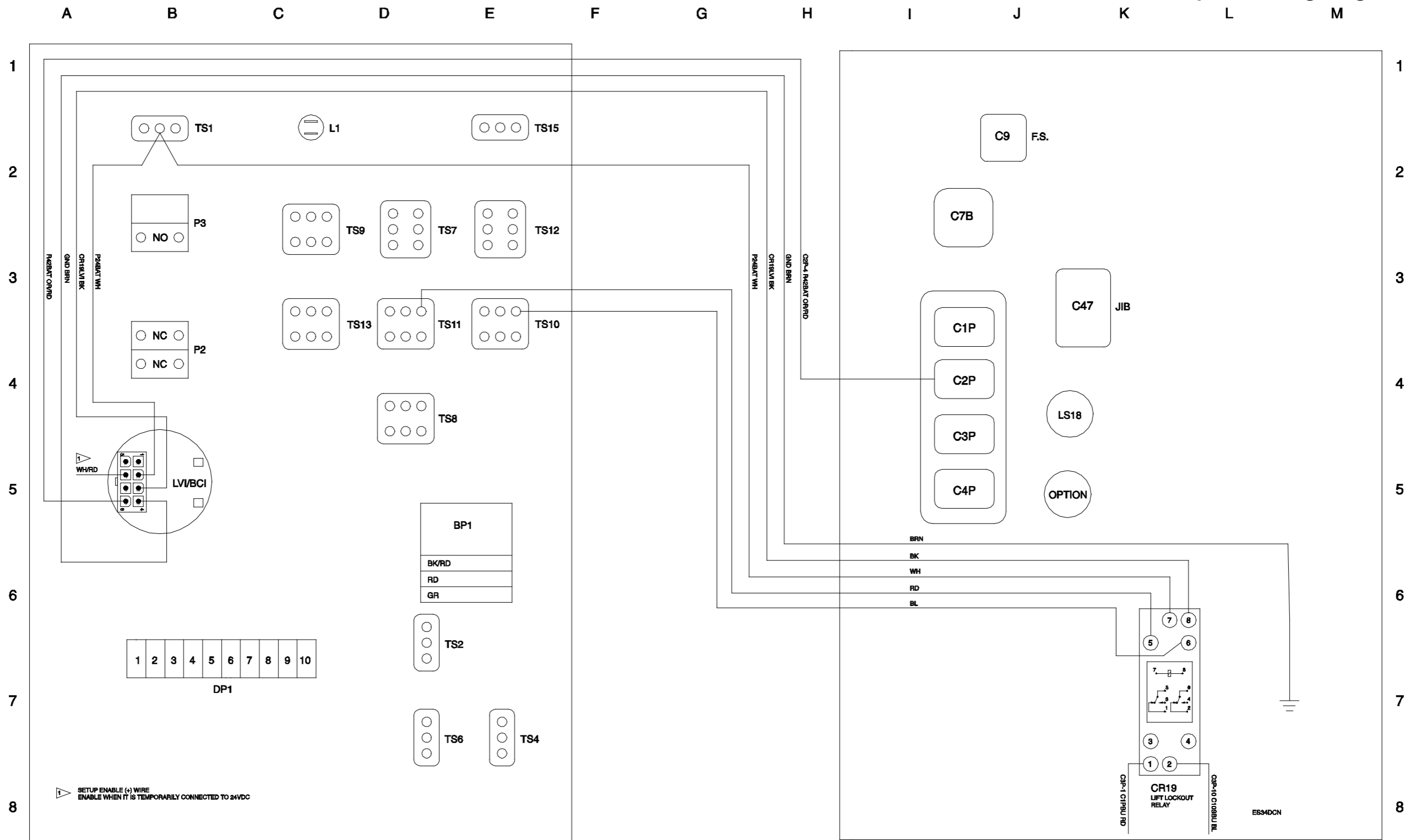

## LVI/BCI Option Wiring Diagram

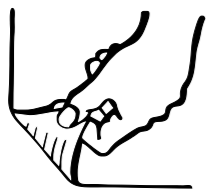

---

## Charger Interlock Option

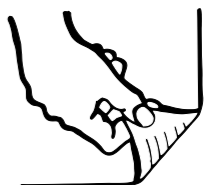

### Charger Interlock Option

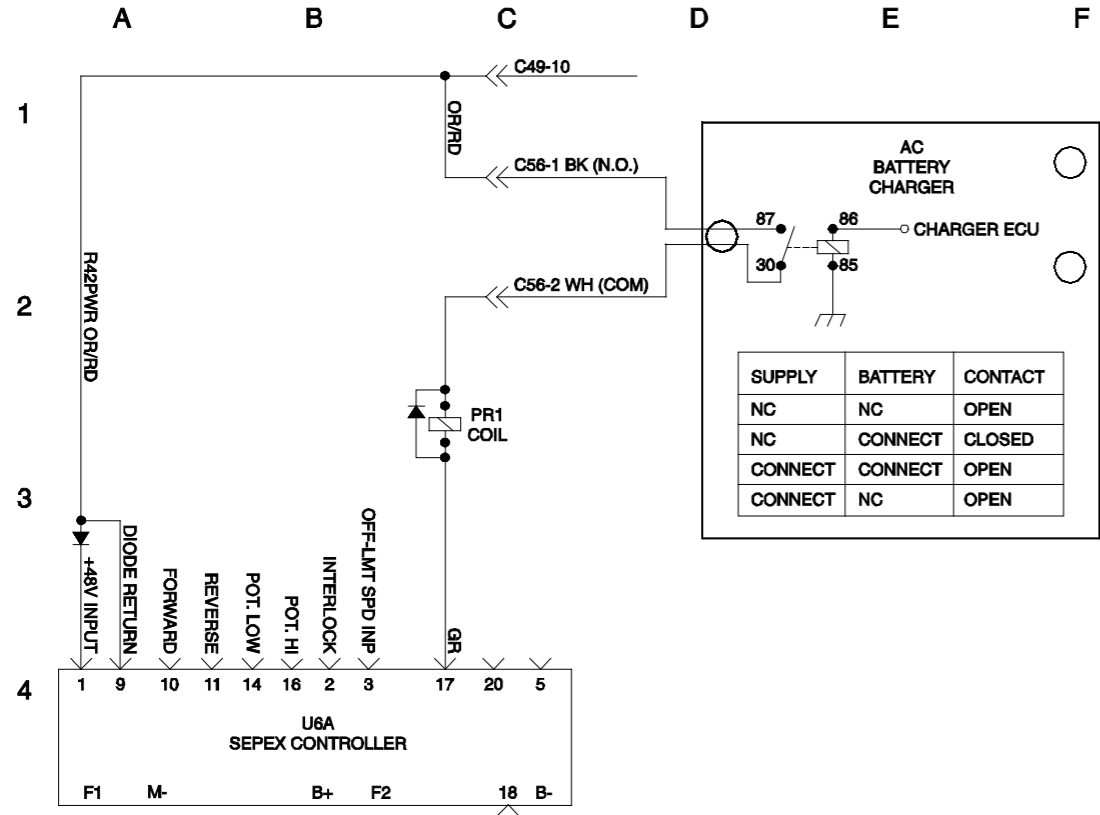

SCHMATIC

- BATTERY INDICATOR LED**
- LED IS RED DURING PHASES I1 AND P (BULK CHARGE). (20% BATTERY CHARGED)
  - LED IS YELLOW DURING PHASES U AND I2. (80% BATTERY CHARGED)
  - LED IS GREEN AT THE END OF CHARGE. (100% BATTERY CHARGED)
  - LED FLASHES GREEN DURING CYCLE EQUALIZATION.
  - LED IS OFF WHEN THE CHARGER IS NOT POWERED.
  - LED FLASHES RED, INDICATES DEFECT / FAULT.

- INTERLOCK RELAY (N.O.), 10A CONTACT**
- CHARGER NOT CONNECTED TO BATTERY OR MAIN SUPPLY, CONTACT OPEN.
  - CHARGER CONNECTED TO BATTERY, CONTACT CLOSED.
  - CHARGER CONNECTED TO BATTERY AND MAIN SUPPLY, CONTACT OPEN.

ES34BEAB

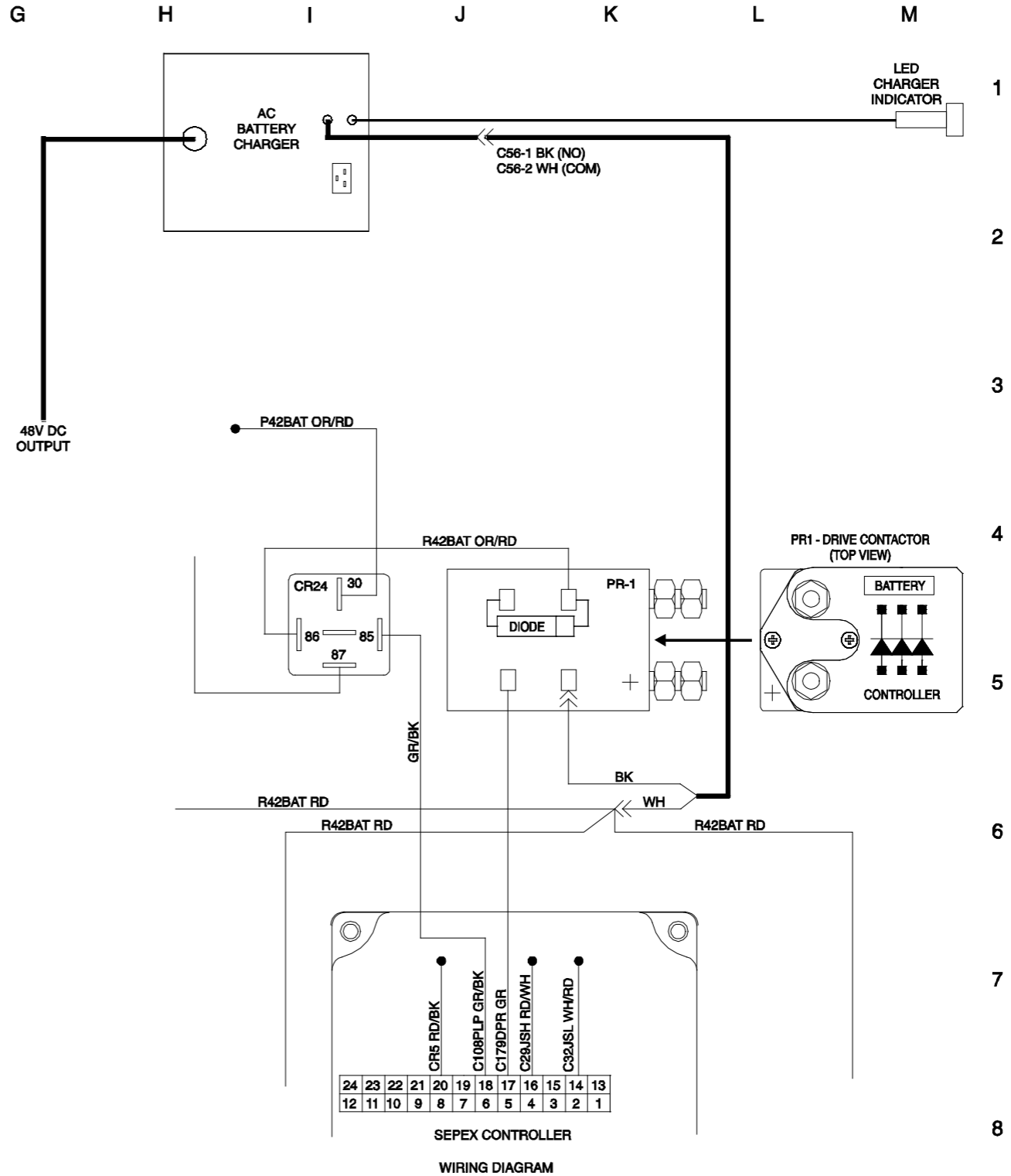

SEPEX CONTROLLER

WIRING DIAGRAM

CTE Option, (CE Models)

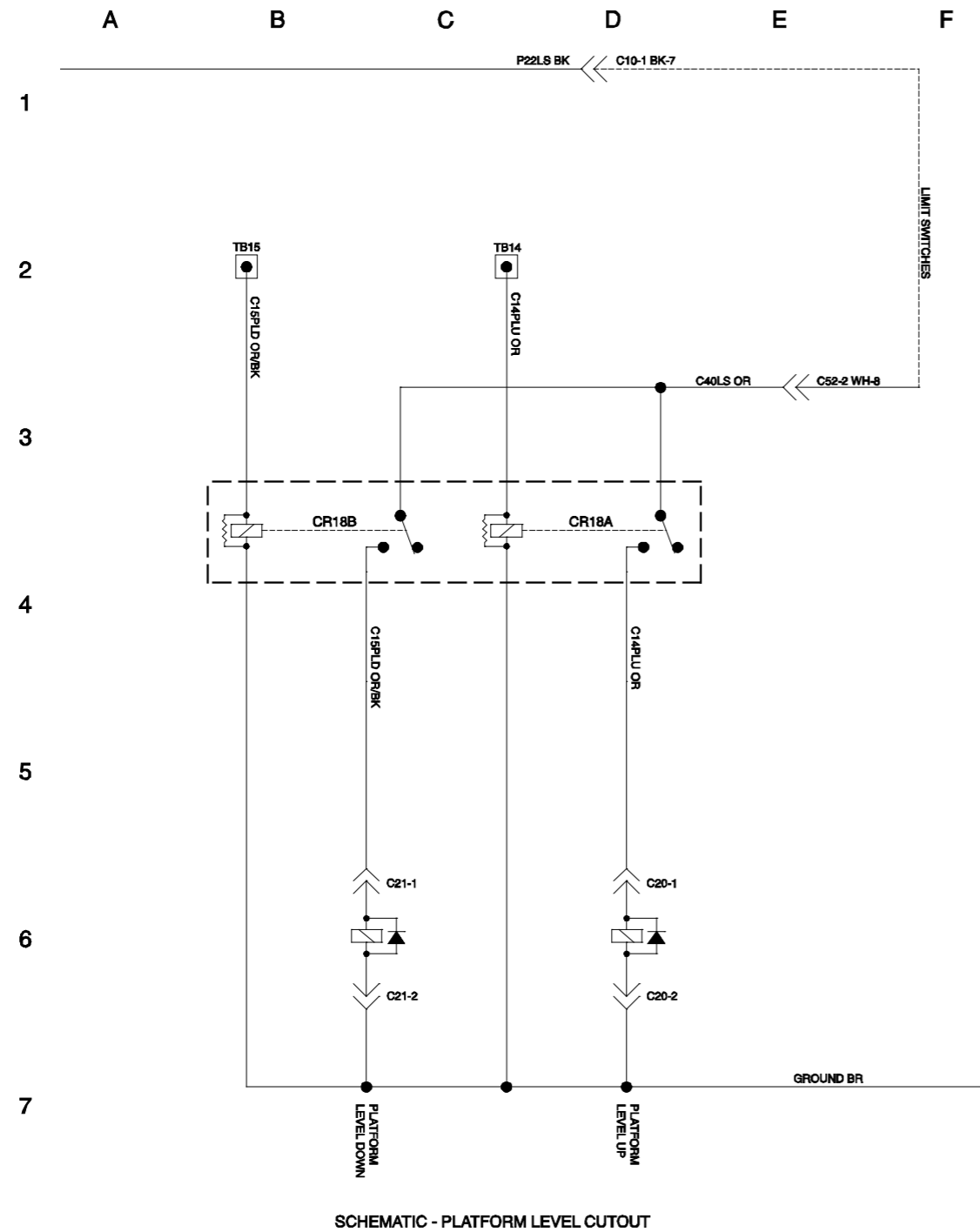

ES0276N

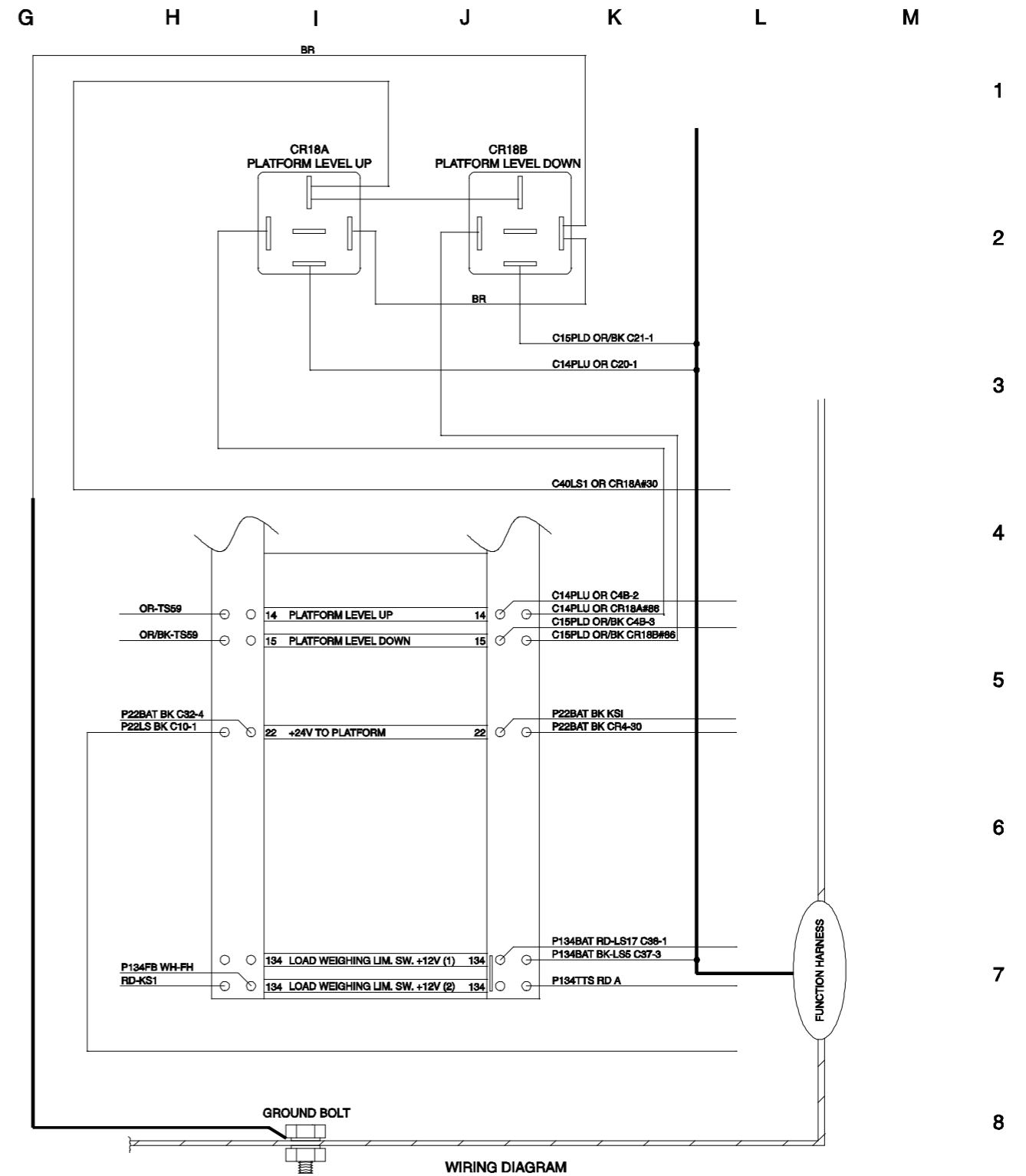

## CTE Option, (CE Models)

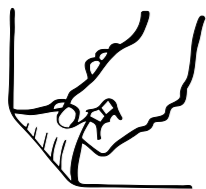



---

## Hydraulic Schematic

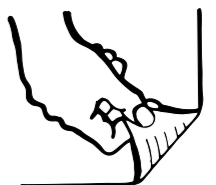

# Hydraulic Schematic

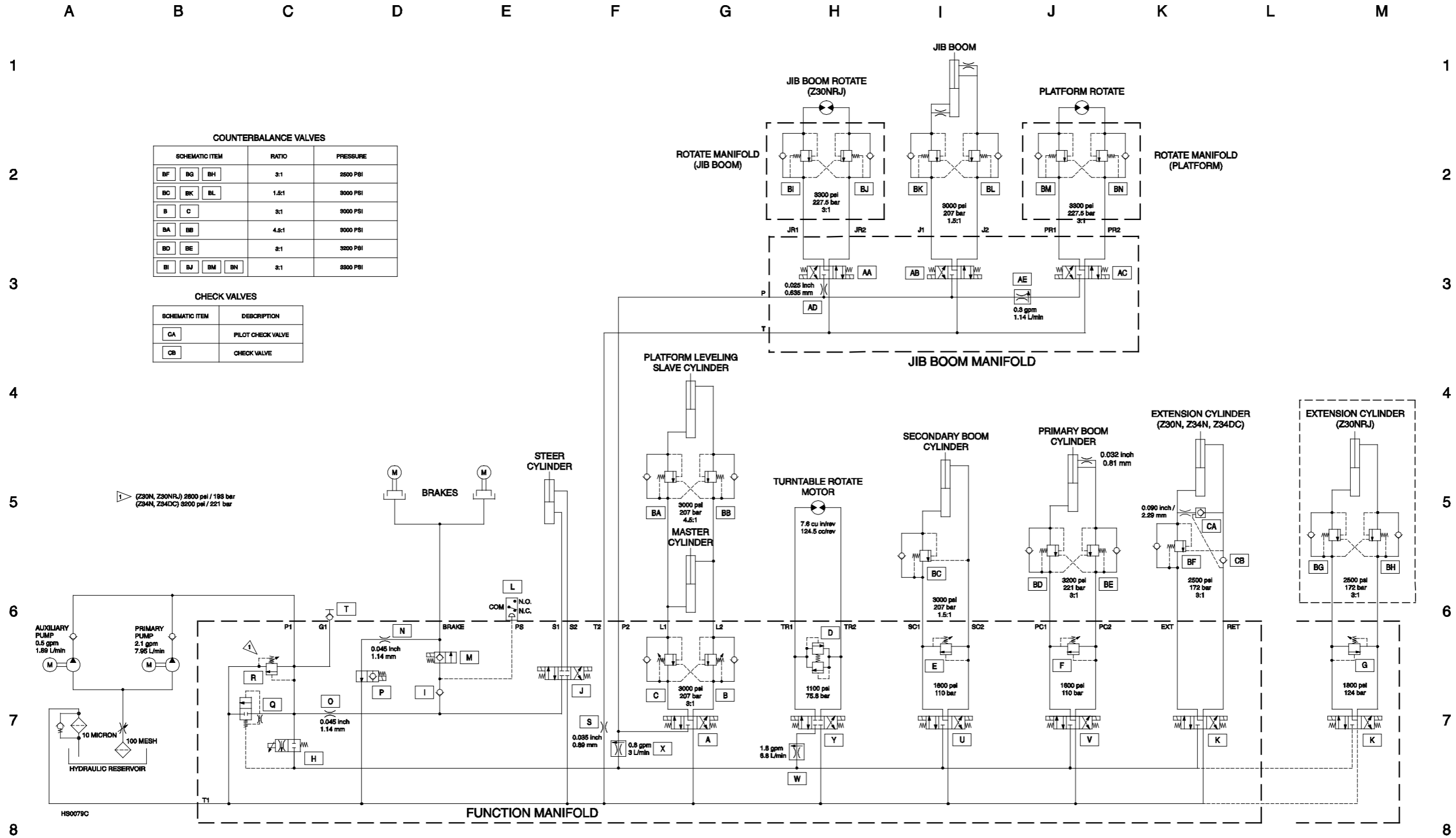

---

**Electrical Schematic, (ANSI / CSA / AS)  
(before serial numbers Z30N10-12119, Z34N10-8857 and Z3410-7774)**

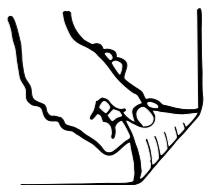

# Electrical Schematic, (ANSI / CSA / AS)

(before serial numbers Z30N10-12119, Z34N10-8857 and Z3410-7774)

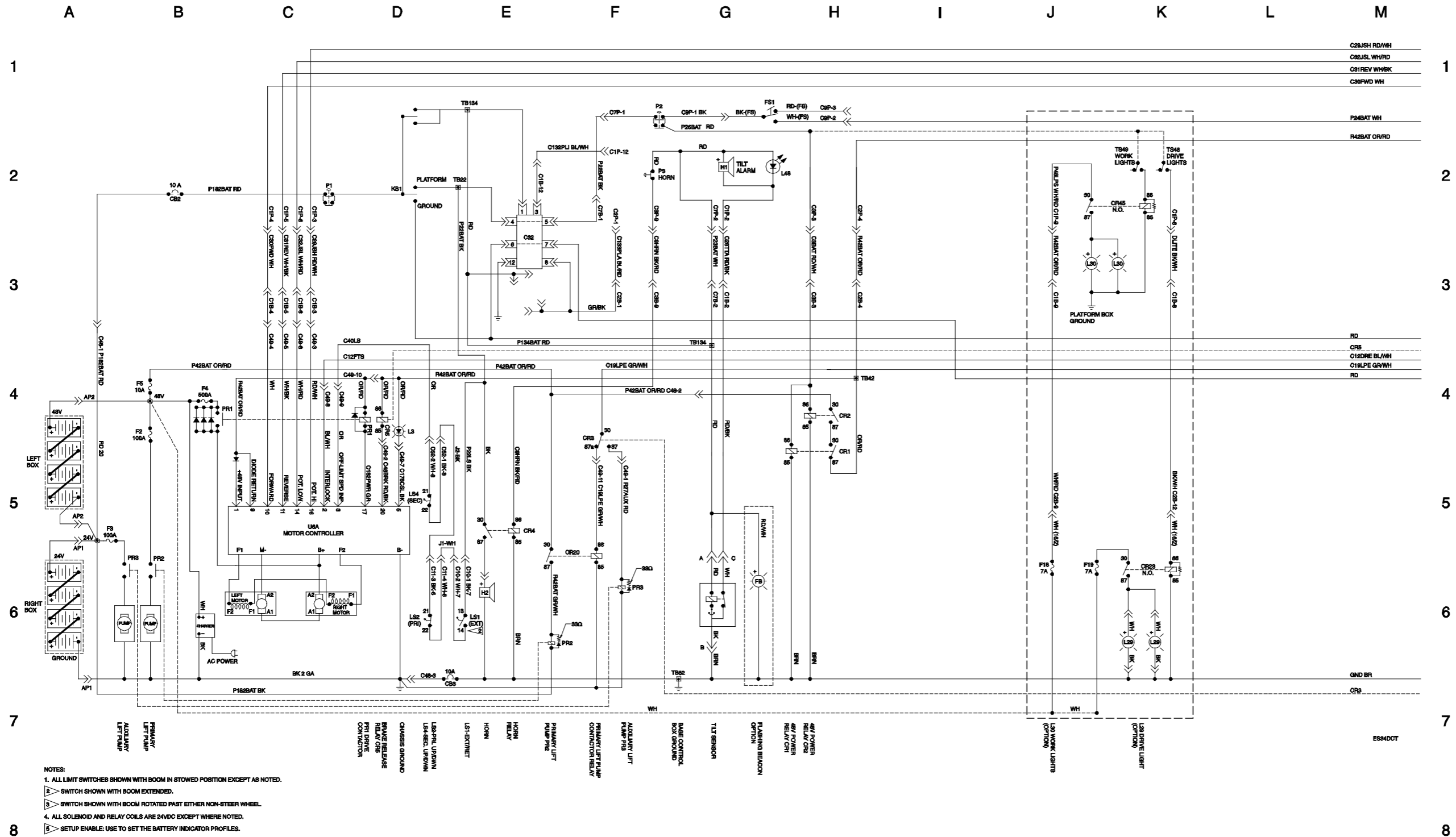

# Electrical Schematic, (ANSI / CSA / AS) (before serial numbers Z30N10-12119, Z34N10-8857 and Z3410-7774)

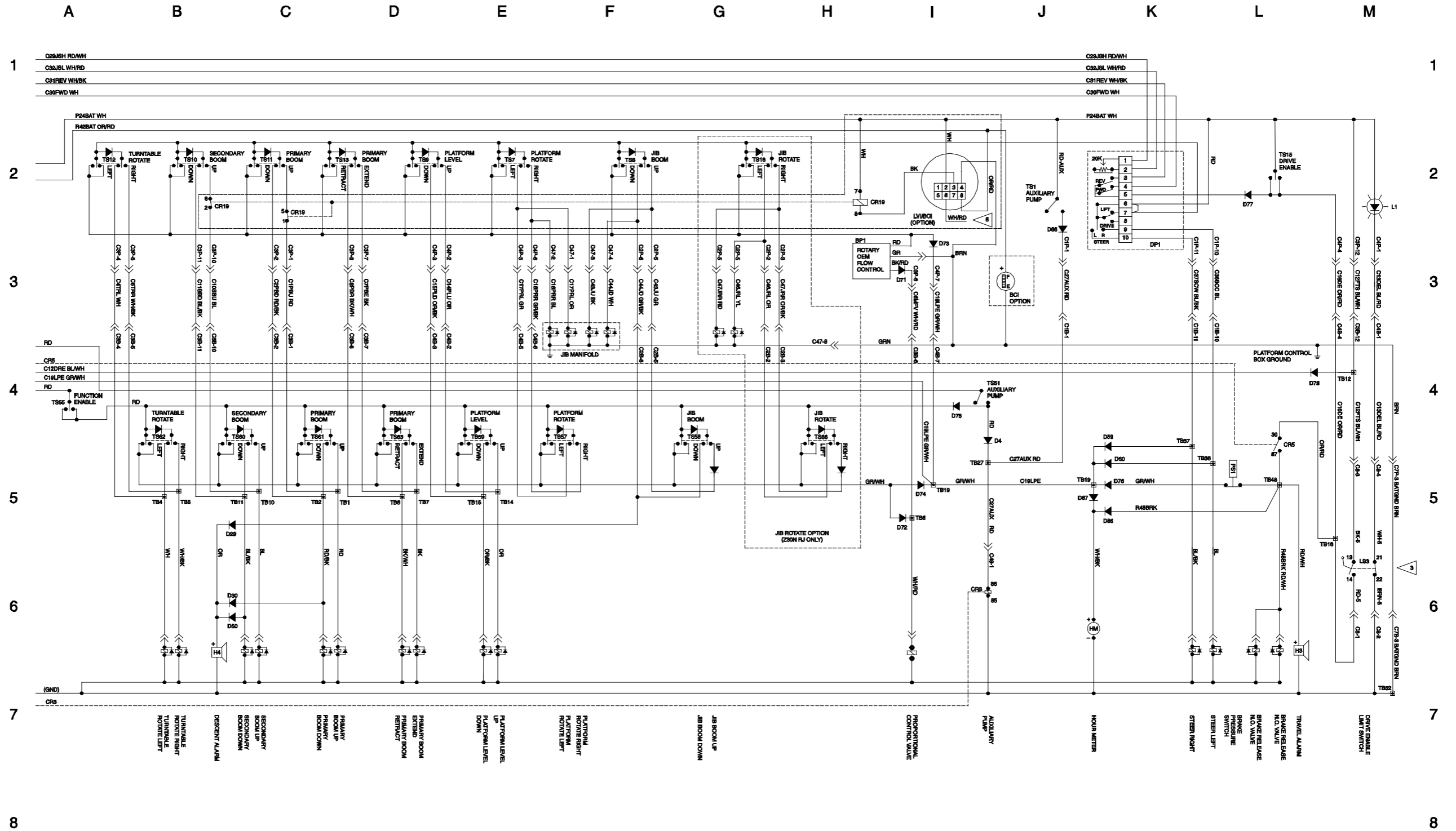

**Electrical Schematic,  
(ANSI / CSA / AS), (before serial numbers Z30N10-12119, Z34N10-8857 and Z3410-7774)**

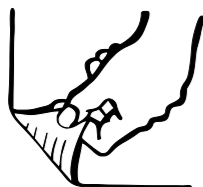

---

**Ground Control Box Terminal Strip Wiring Diagram, (ANSI / CSA / AS)  
(before serial numbers Z3010-12119, Z34N10-8857 and Z3410-7774)**

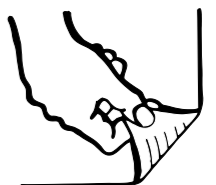

# Ground Control Box Terminal Strip Wiring Diagram, (ANSI / CSA / AS)

(before serial numbers Z3010-12119, Z34N10-8857 and Z3410-7774)

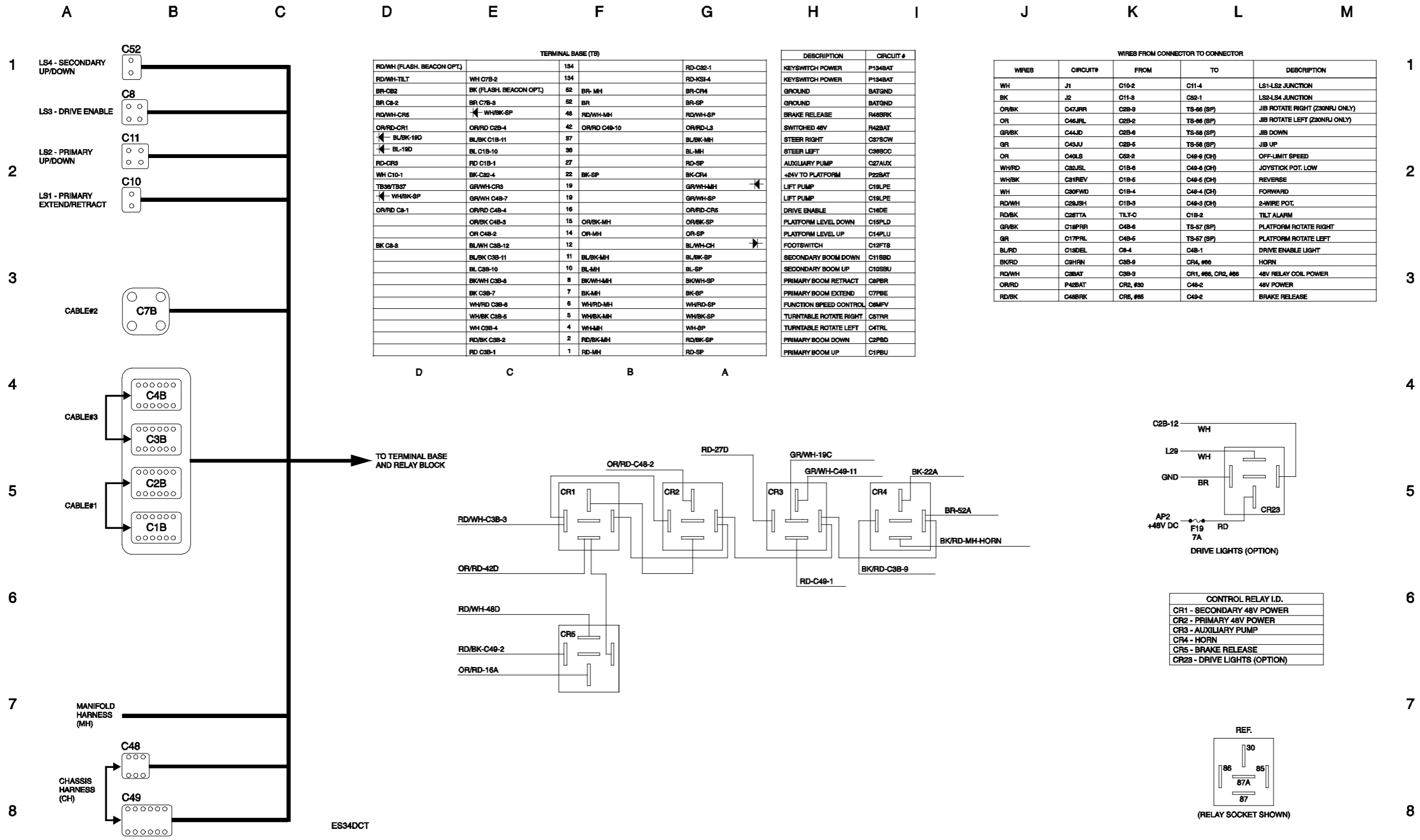



### Ground Control Box Switch Panel Wiring Diagram, (ANSI / CSA / AS) (before serial numbers Z30N10-12119, Z34N10-8857 and Z3410-7774)

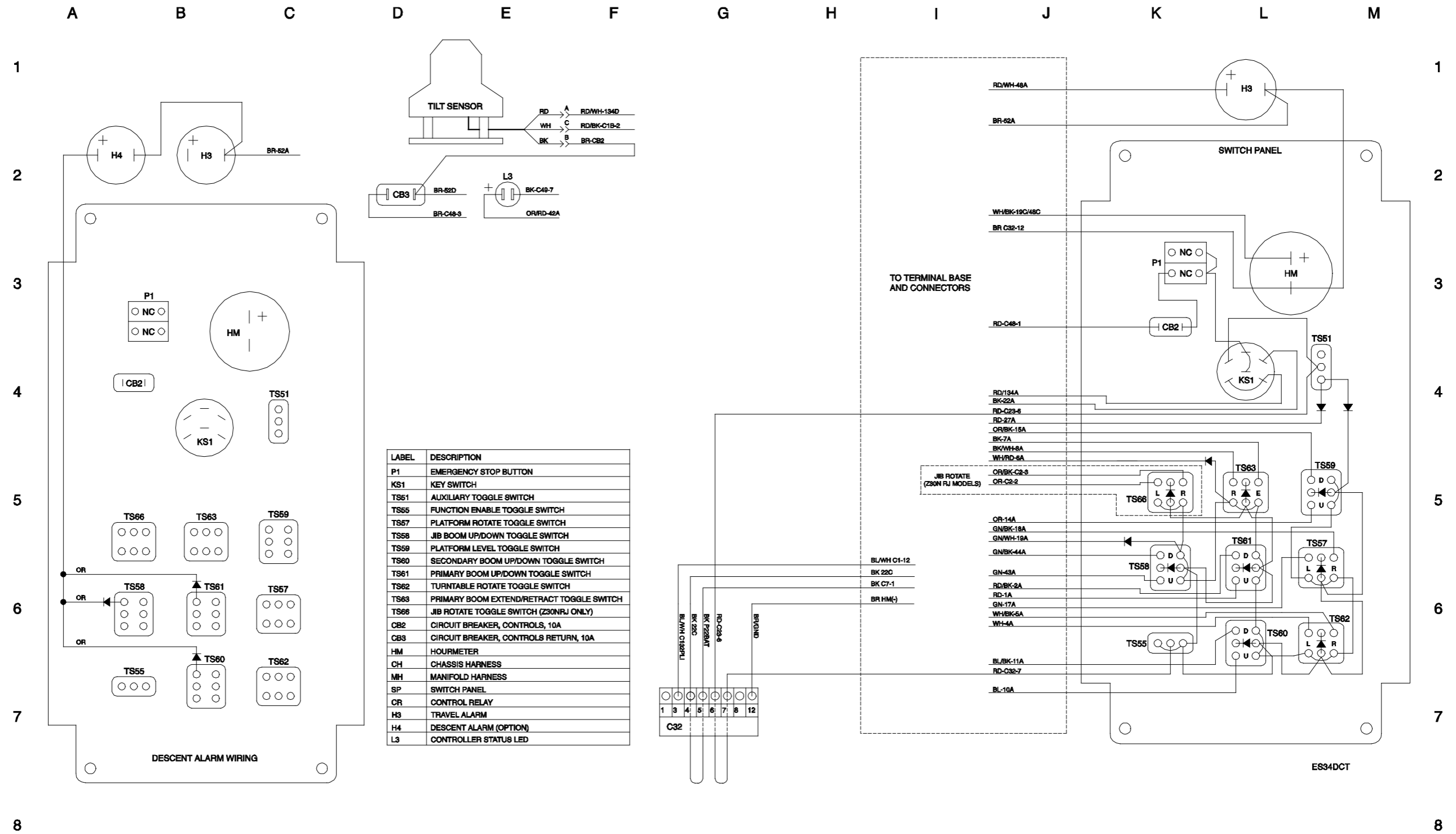

**Ground Control Box Switch Panel Wiring Diagram, (ANSI / CSA / AS)  
(before serial numbers Z30N10-12119, Z34N10-8857 and Z3410-7774)**

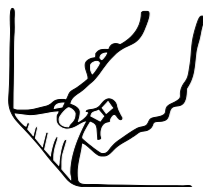

---

**Platform Control Box Wiring Diagram, (ANSI / CSA / AS)  
(before serial numbers Z30N10-12119, Z34N10-8857 and Z3410-7774)**

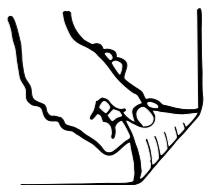

# Platform Control Box Wiring Diagram, (ANSI / CSA / AS)

(before serial numbers Z30N10-12119, Z34N10-8857 and Z3410-7774)

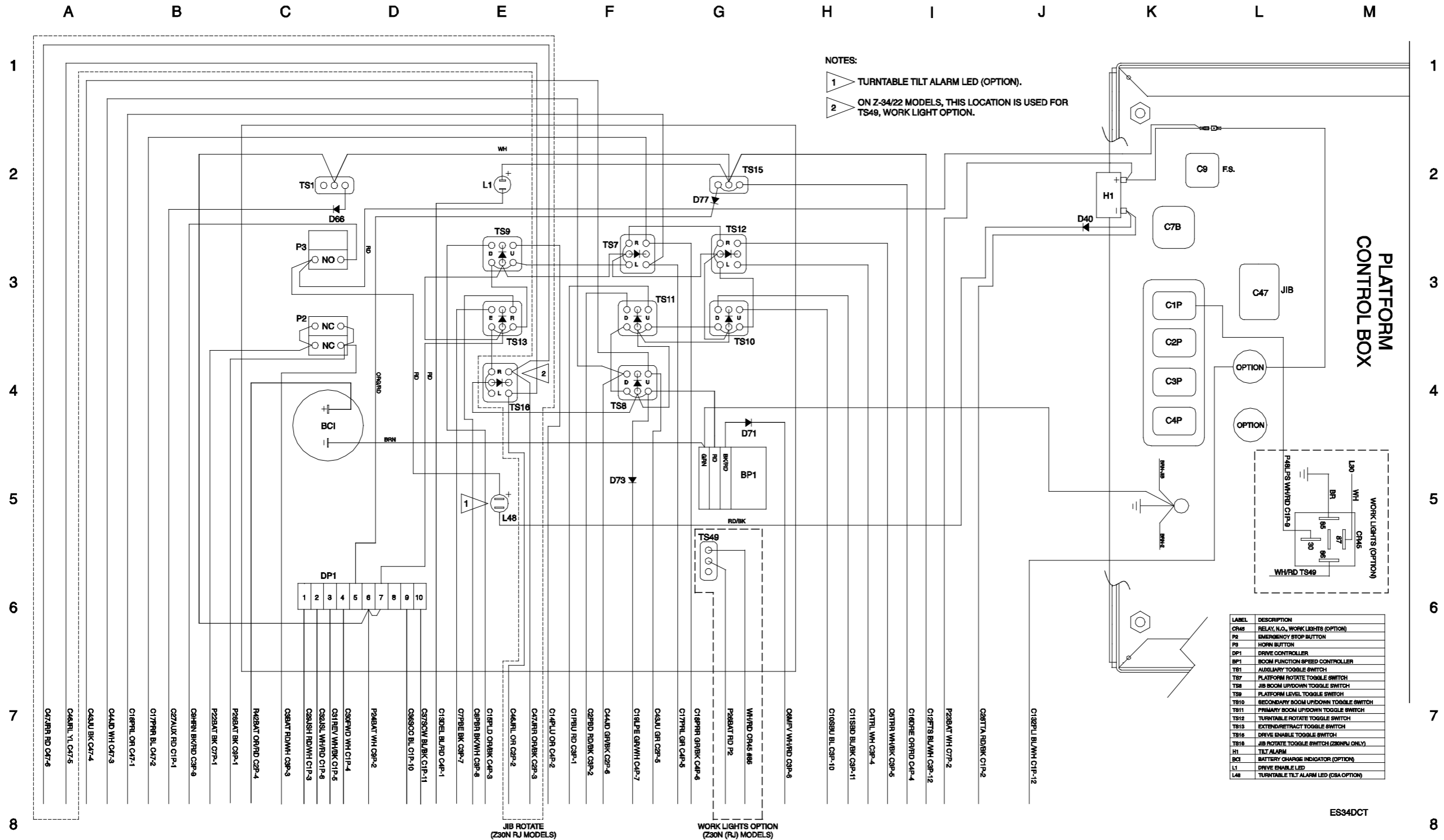

---

**Electrical Schematic, (CE),  
(before serial numbers Z30N10-12119, Z34N10-8857 and Z3410-7774)**

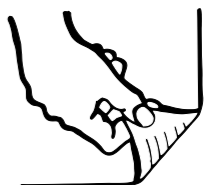

# Electrical Schematic, (CE), (before serial numbers Z30N10-12119, Z34N10-8857 and Z3410-7774)

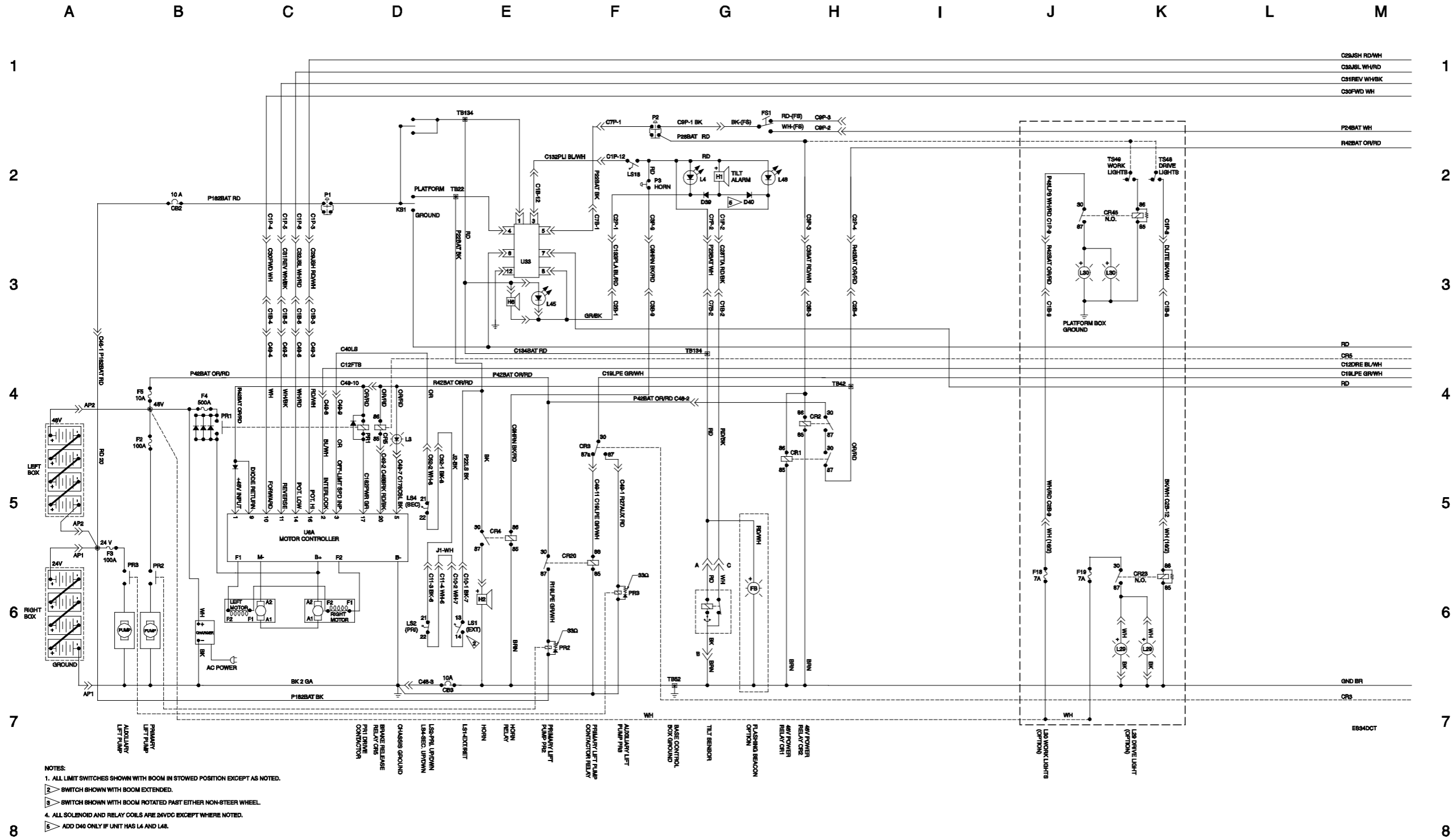

# Electrical Schematic, (CE), (before serial numbers Z30N10-12119, Z34N10-8857 and Z3410-7774)

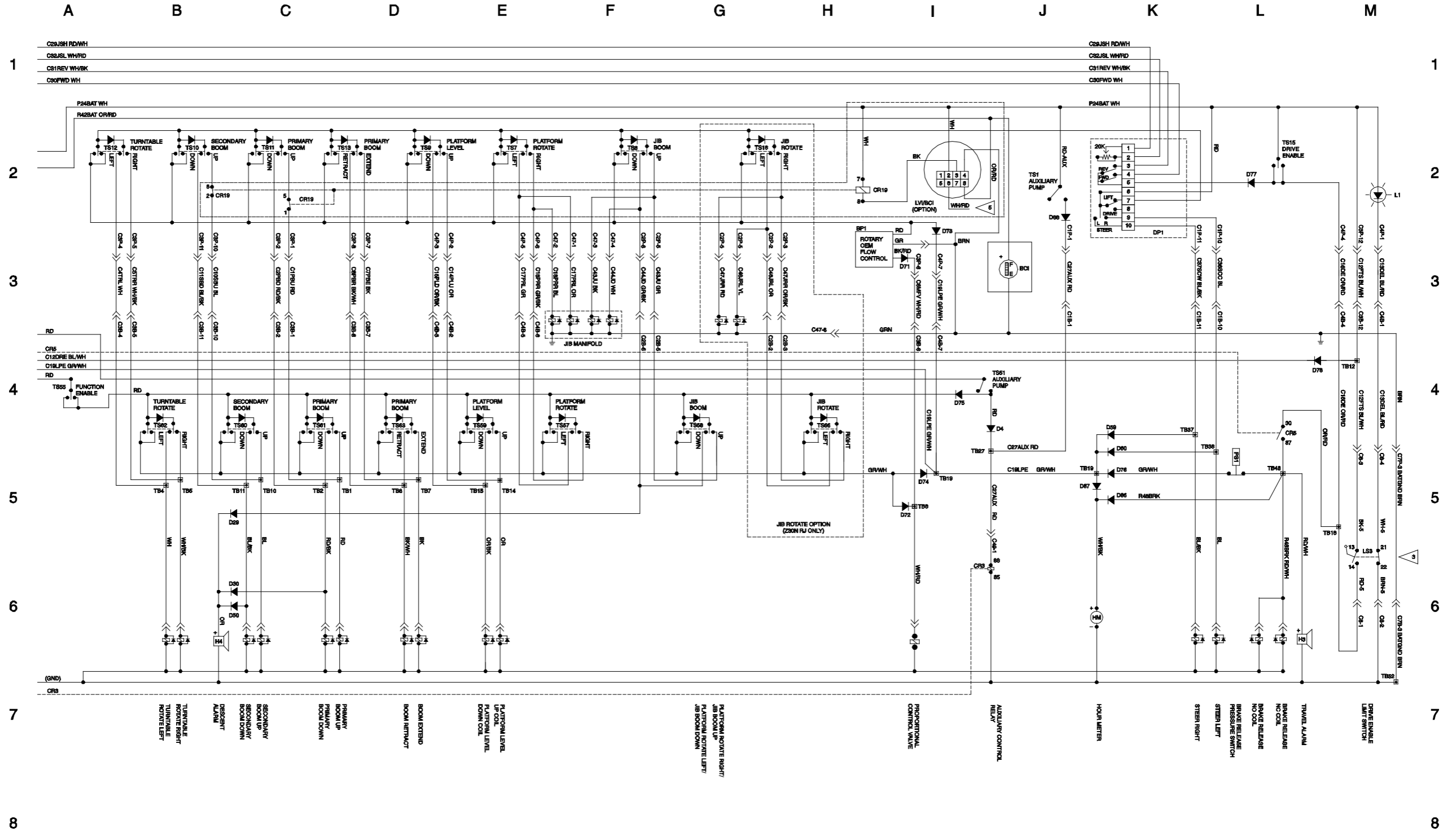

**Electrical Schematic, (CE),  
(before serial numbers Z30N10-12119, Z34N10-8857 and Z3410-7774)**

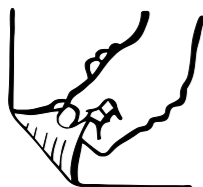



---

**Ground Control Box Terminal Strip Wiring Diagram, (CE),  
(before serial numbers Z30N10-12119, Z34N10-8857 and Z3410-7774)**

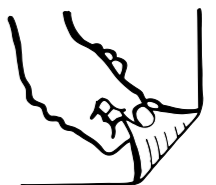

# Ground Control Box Terminal Strip Wiring Diagram, (CE)

(before serial numbers Z30N10-12119, Z34N10-8857 and Z3410-7774)

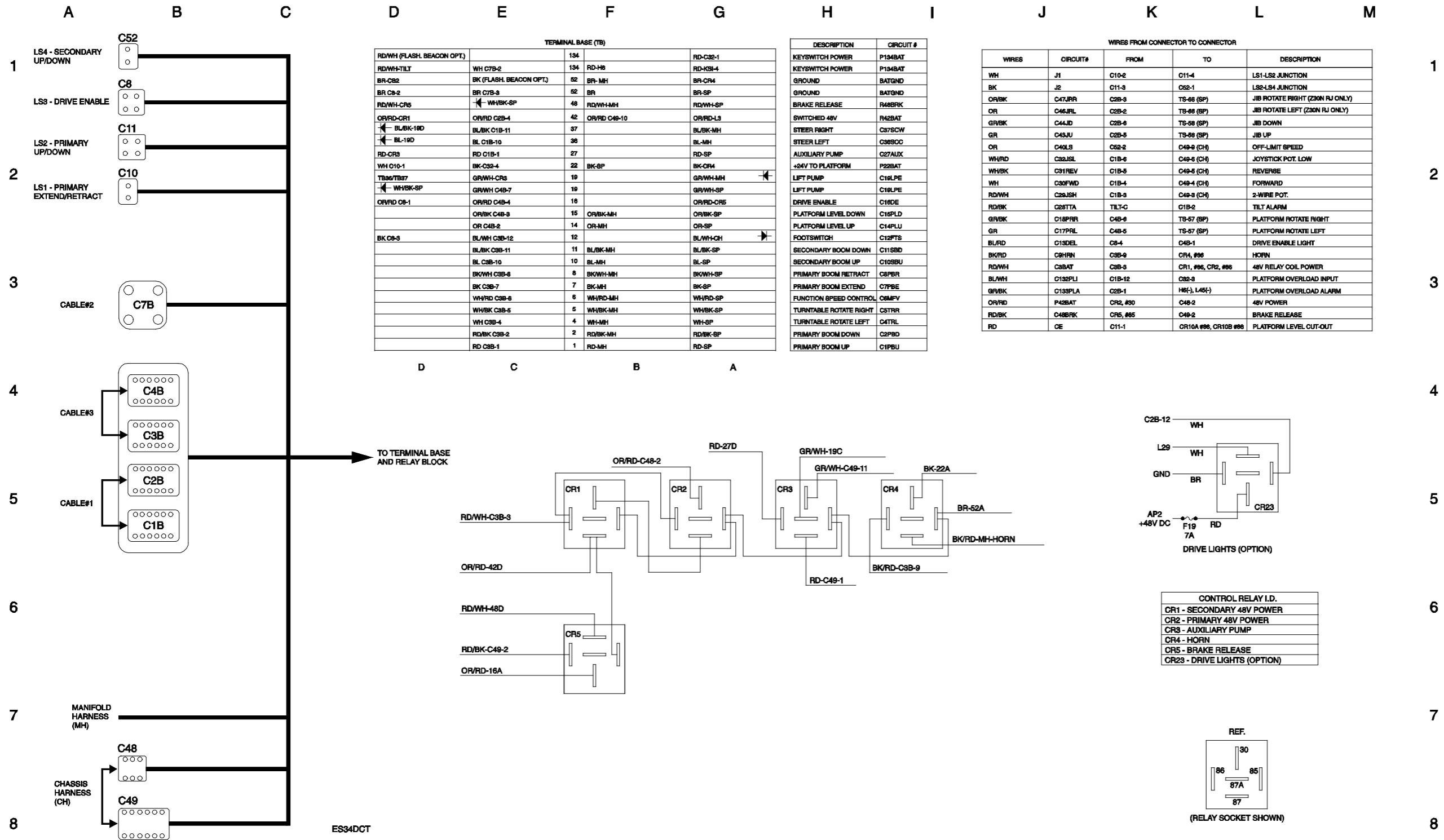

### Ground Control Box Switch Panel Wiring Diagram, (CE) (before serial numbers Z30N10-12119, Z34N10-8857 and Z3410-7774)

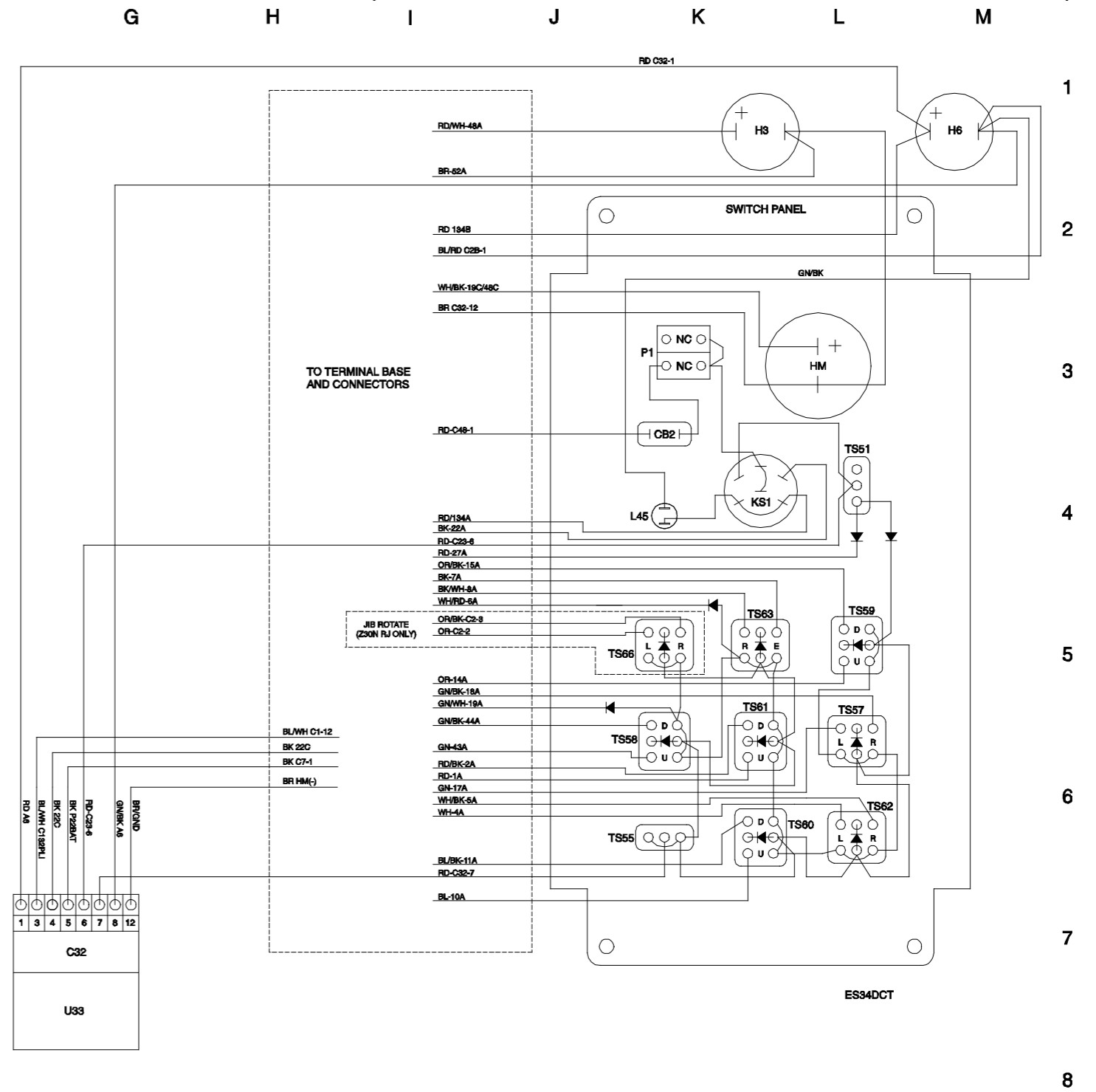
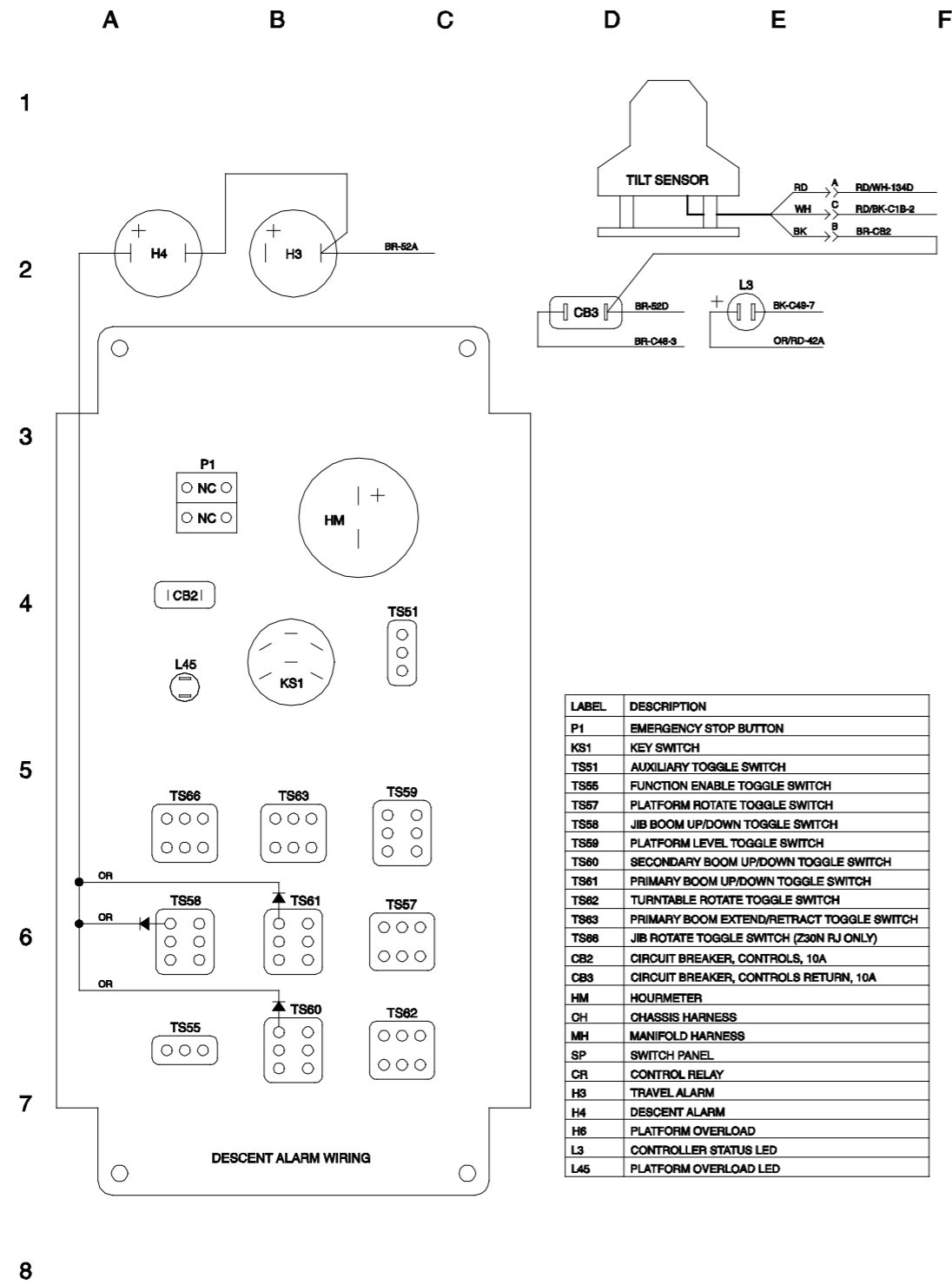

**Ground Control Box Switch Panel Wiring Diagram, (CE)  
(before serial numbers Z30N10-12119, Z34N10-8857 and Z3410-7774)**

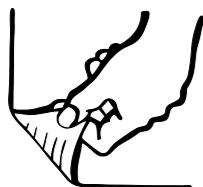

---

**Platform Control Box Wiring Diagram, (CE)**  
**(before serial numbers Z30N10-12119, Z34N10-8857 and Z3410-7774)**

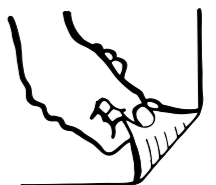

# Platform Control Box Wiring Diagram, (CE)

(before serial numbers Z30N10-12119, Z34N10-8857 and Z3410-7774)

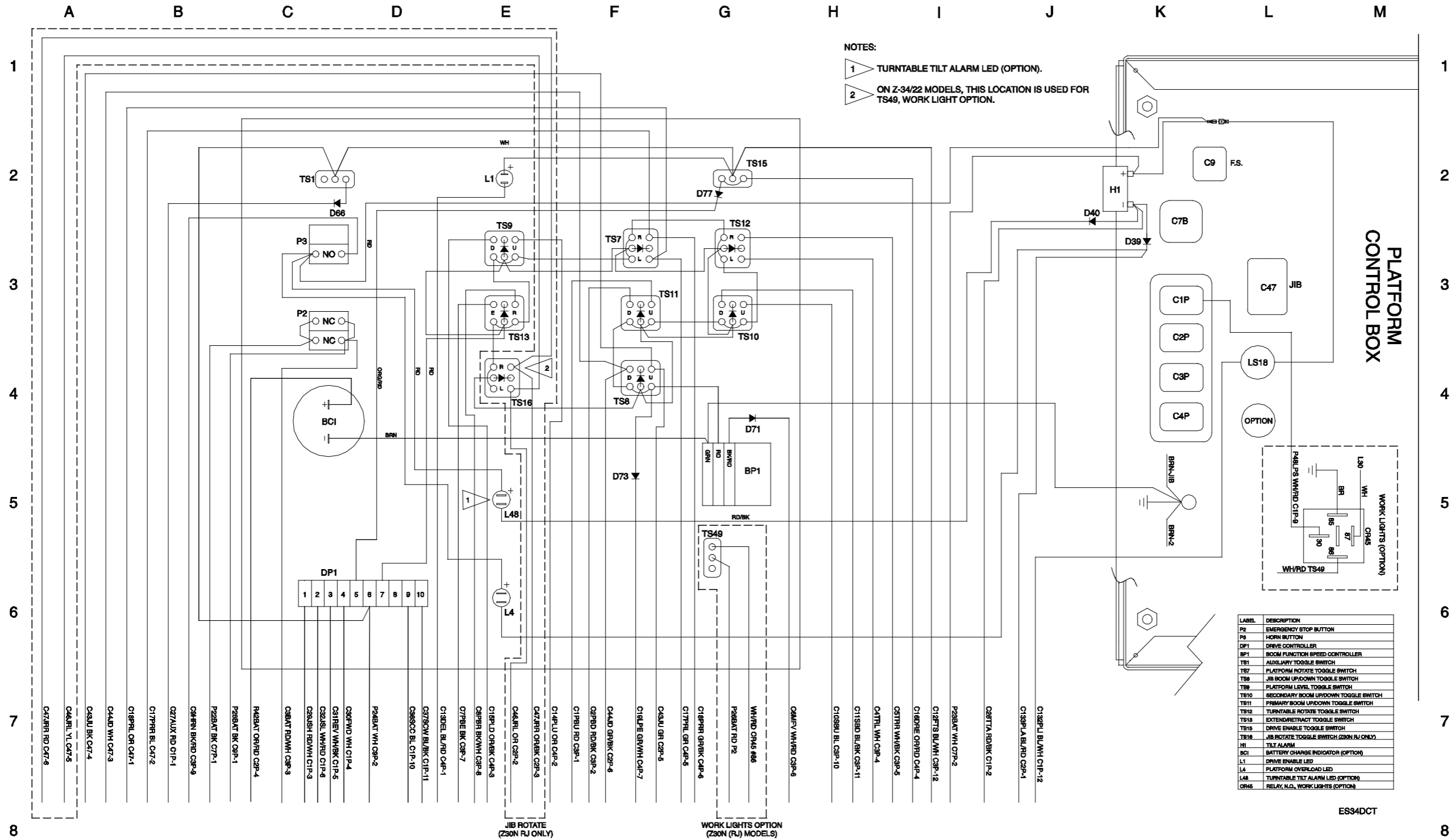

---

**Electrical Schematic, (ANSI / CSA),  
(from serial numbers Z30N10-12119, Z34N10-8857 and Z3410-7774)**

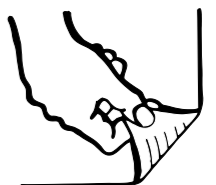

# Electrical Schematic, (ANSI / CSA)

(from serial numbers Z30N10-12119, Z34N10-8857 and Z3410-7774)

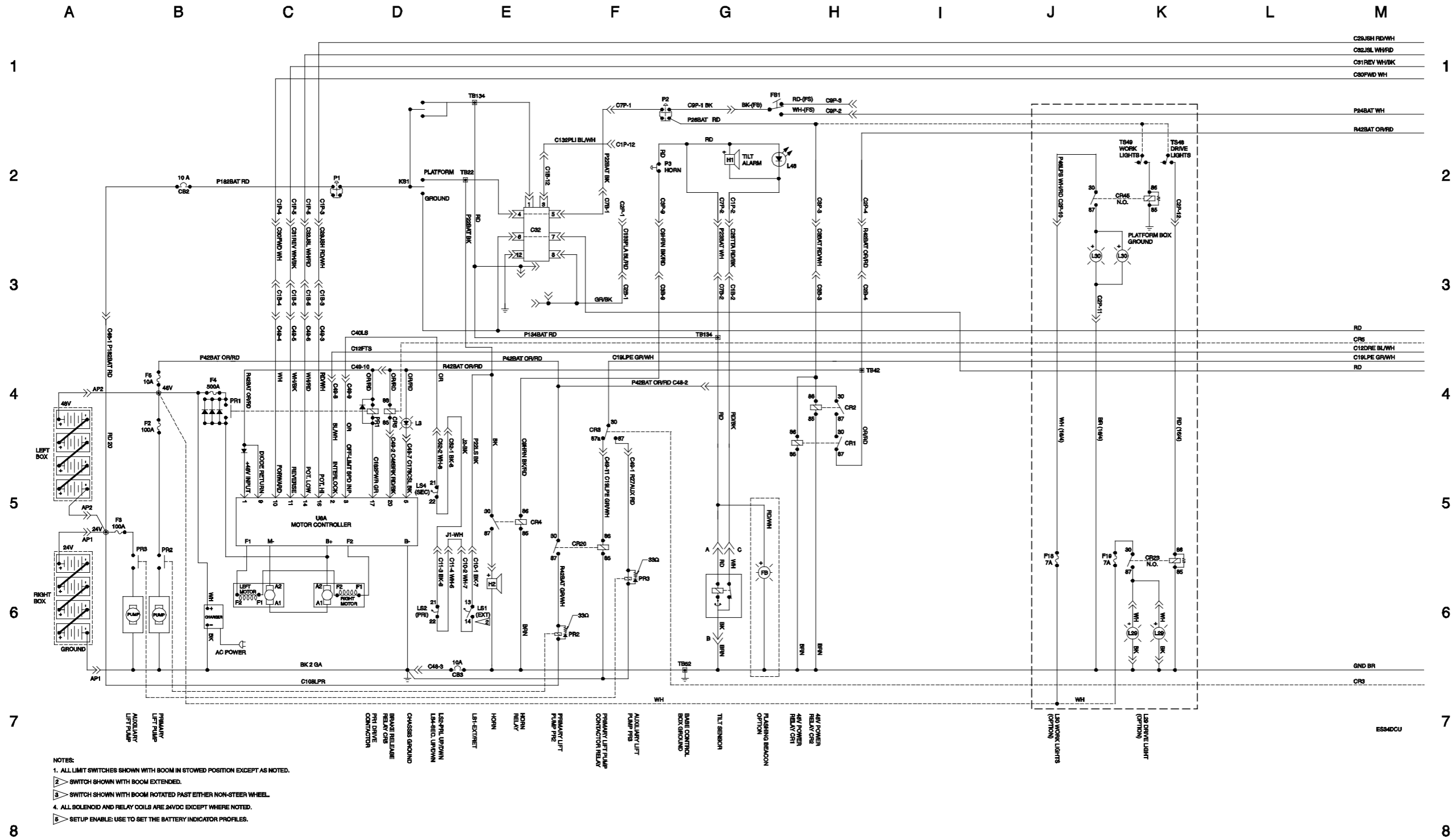



# Electrical Schematic, (ANSI / CSA) (from serial numbers Z30N10-12119, Z34N10-8857 and Z3410-7774)

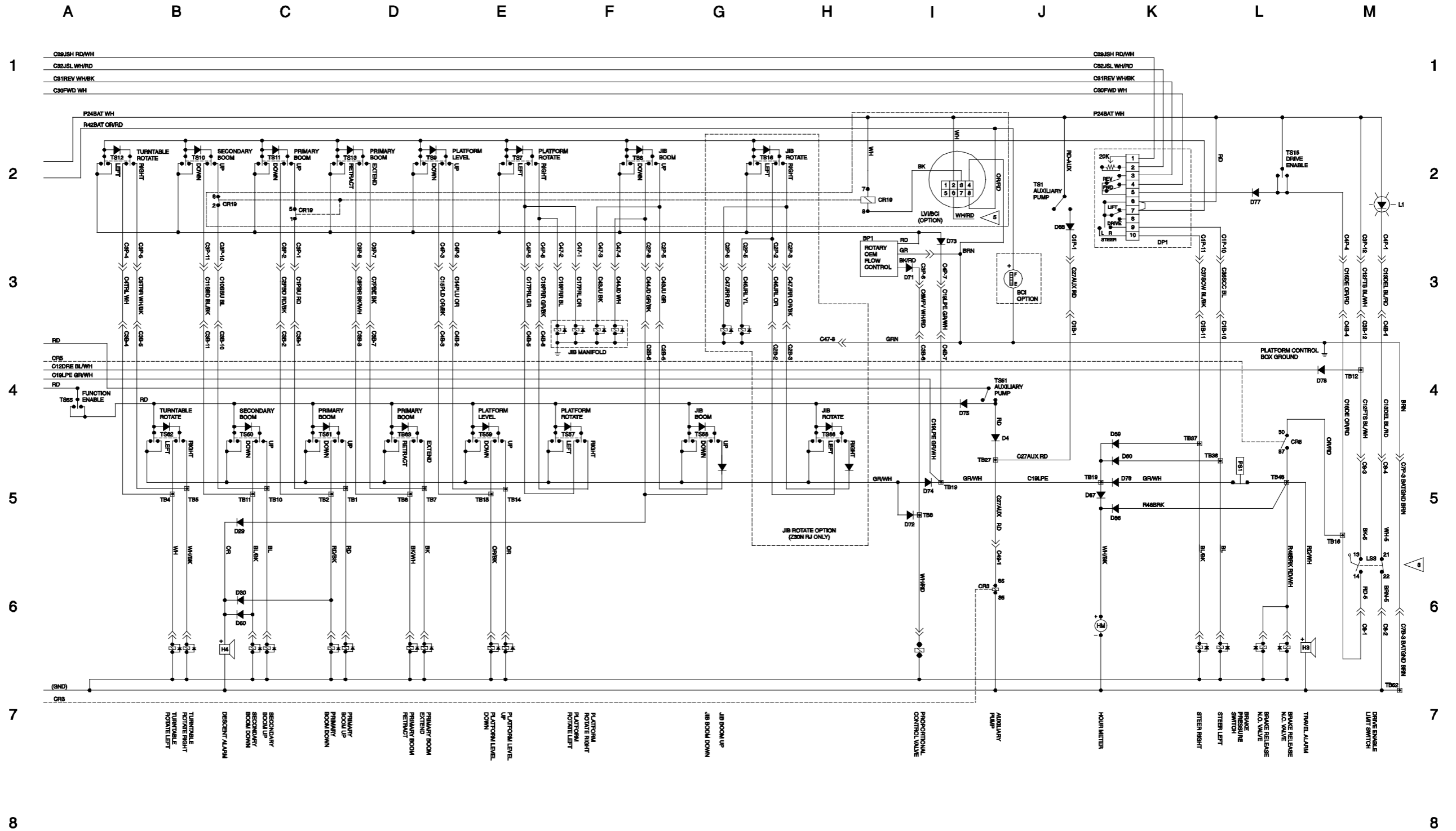

**Electrical Schematic, (ANSI / CSA),  
(from serial numbers Z30N10-12119, Z34N10-8857 and Z3410-7774)**

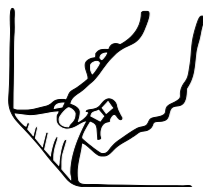

---

**Ground Control Box Terminal Strip Wiring Diagram, (ANSI / CSA),  
(from serial numbers Z30N10-12119, Z34N10-8857 and Z3410-7774)**

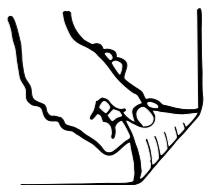

# Ground Control Box Terminal Strip Wiring Diagram, (ANSI / CSA)

(from serial numbers Z30N10-12119, Z34N10-8857 and Z3410-7774)

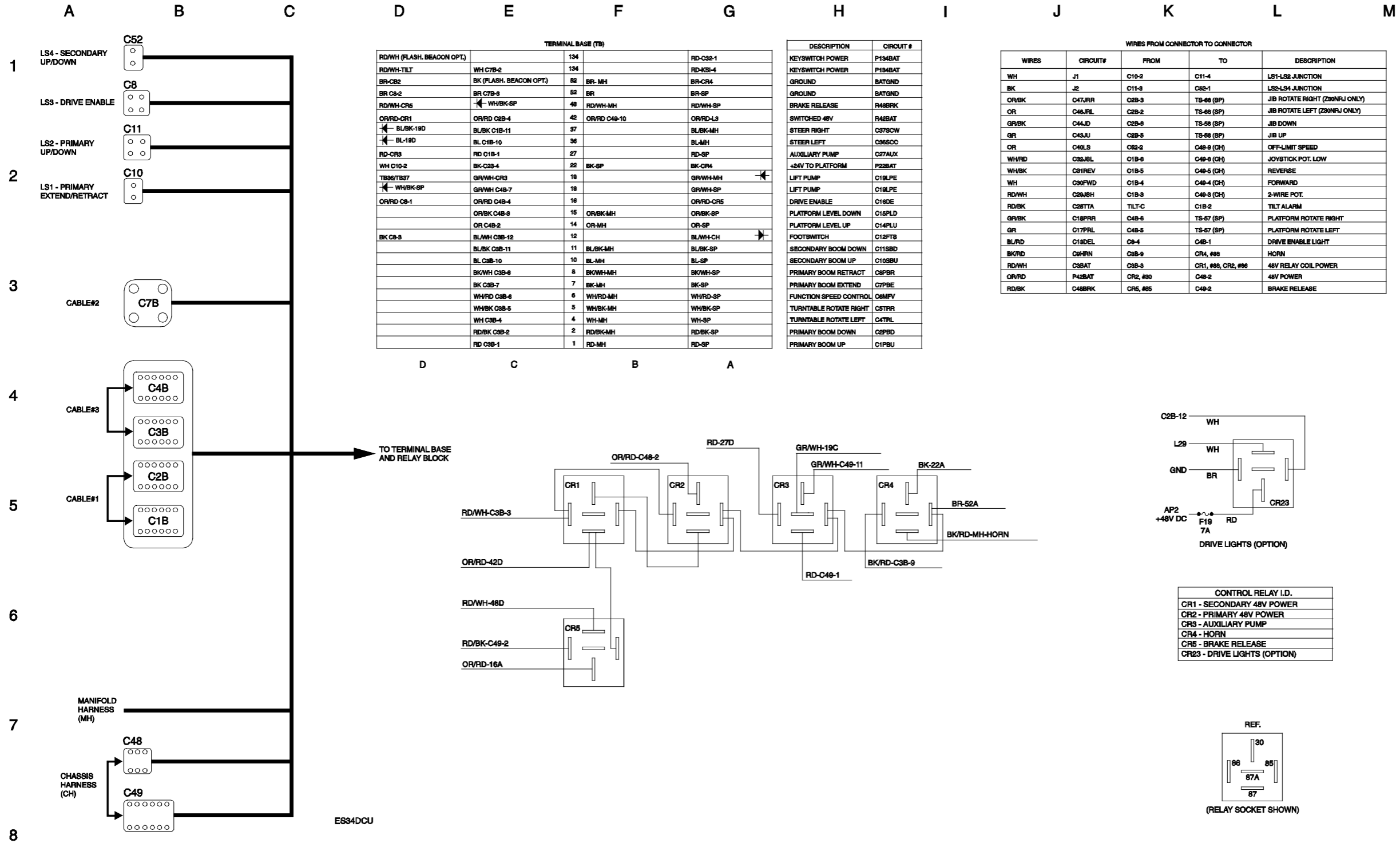

TERMINAL BASE (TB)			
RD/WH (FLASH, BEACON OPT.)		134	RD-C32-1
RD/WH-TILT	WH C7B-2	134	RD-KSI-4
BR-CB2	BK (FLASH, BEACON OPT.)	52	BR-CR4
BR C2-2	BR C7B-3	52	BR-SP
RD/WH-CR5	WH/BK-SP	48	RD/WH-SP
OR/RD-CR1	OR/RD C2B-4	42	OR/RD-LS
	BL/BK-19D	37	BL/BK-MH
	BL C1B-10	36	BL-MH
RD-CR3	RD C1B-1	27	RD-SP
WH C10-2	BK-C2B-4	22	BK-SP
TB36/TB37	GR/WH-CR3	18	GR/WH-MH
	WH/BK-SP	18	GR/WH-SP
OR/RD C2-1	OR/RD C4B-4	16	OR/RD-CR5
	OR/BK C4B-9	15	OR/BK-MH
	OR C4B-2	14	OR-SP
BK C2-3	BL/WH C2B-12	12	BL/WH-CH
	BL/BK C2B-11	11	BL/BK-MH
	BL C2B-10	10	BL-SP
	BK/WH C2B-8	8	BK/WH-MH
	BK C2B-7	7	BK-SP
	WH/RD C2B-6	6	WH/RD-SP
	WH/BK C2B-5	5	WH/BK-SP
	WH C2B-4	4	WH-SP
	RD/BK C2B-2	2	RD/BK-MH
	RD C2B-1	1	RD-MH

DESCRIPTION	CIRCUIT #
KEYSWITCH POWER	P134BAT
KEYSWITCH POWER	P134BAT
GROUND	BATGND
GROUND	BATGND
BRAKE RELEASE	R48BRK
SWITCHED 48V	R48BAT
STEER RIGHT	C373OW
STEER LEFT	C363CC
AUXILIARY PUMP	C27AUX
+24V TO PLATFORM	P22BAT
LIFT PUMP	C19LPE
LIFT PUMP	C19LPE
DRIVE ENABLE	C18DE
PLATFORM LEVEL DOWN	C18PLD
PLATFORM LEVEL UP	C14PLU
FOOTSWITCH	C12FTB
SECONDARY BOOM DOWN	C103BD
SECONDARY BOOM UP	C103BU
PRIMARY BOOM RETRACT	C8PBR
PRIMARY BOOM EXTEND	C7PBE
FUNCTION SPEED CONTROL	C6MPV
TURNTABLE ROTATE RIGHT	C5TRR
TURNTABLE ROTATE LEFT	C4TRL
PRIMARY BOOM DOWN	C2PBD
PRIMARY BOOM UP	C1PBU

WIRES FROM CONNECTOR TO CONNECTOR				
WIRES	CIRCUIT#	FROM	TO	DESCRIPTION
WH	J1	C10-2	C11-4	LS1-LS2 JUNCTION
BK	J2	C11-9	C2B-1	LS2-LS4 JUNCTION
OR/BK	C47JRR	C2B-3	TS-68 (SP)	JIB ROTATE RIGHT (Z30N1J ONLY)
OR	C46JRL	C2B-2	TS-68 (SP)	JIB ROTATE LEFT (Z30N1J ONLY)
GR/BK	C44JD	C2B-6	TS-58 (SP)	JIB DOWN
GR	C43JU	C2B-5	TS-58 (SP)	JIB UP
OR	C40LS	C2B-2	C4B-9 (CH)	OFF-LIMIT SPEED
WH/RD	C38JBL	C1B-6	C4B-9 (CH)	JOYSTICK POT. LOW
WH/BK	C31REV	C1B-5	C4B-5 (CH)	REVERSE
WH	C30FWD	C1B-4	C4B-4 (CH)	FORWARD
RD/WH	C28J8H	C1B-3	C4B-3 (CH)	2-WIRE POT.
RD/BK	C28TTA	TILT-C	C1B-2	TILT ALARM
GR/BK	C18PRR	C4B-6	TS-57 (SP)	PLATFORM ROTATE RIGHT
GR	C17PRL	C4B-5	TS-57 (SP)	PLATFORM ROTATE LEFT
BL/RD	C18DEL	C2-4	C4B-1	DRIVE ENABLE LIGHT
BK/RD	C28HRN	C2B-9	CR4, #85	HORN
RD/WH	C38BAT	C2B-3	CR1, #85, CR2, #86	48V RELAY COIL POWER
OR/RD	P42BAT	CR2, #80	C4B-2	48V POWER
RD/BK	C48BRK	CR5, #85	C4B-2	BRAKE RELEASE

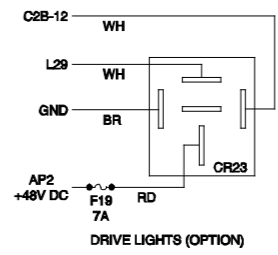

CONTROL RELAY I.D.	
CR1	SECONDARY 48V POWER
CR2	PRIMARY 48V POWER
CR3	AUXILIARY PUMP
CR4	HORN
CR5	BRAKE RELEASE
CR23	DRIVE LIGHTS (OPTION)

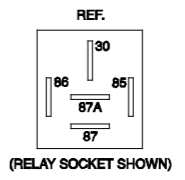

### Ground Control Box Switch Panel Wiring Diagram, (ANSI / CSA) (from serial numbers Z30N10-12119, Z34N10-8857 and Z3410-7774)

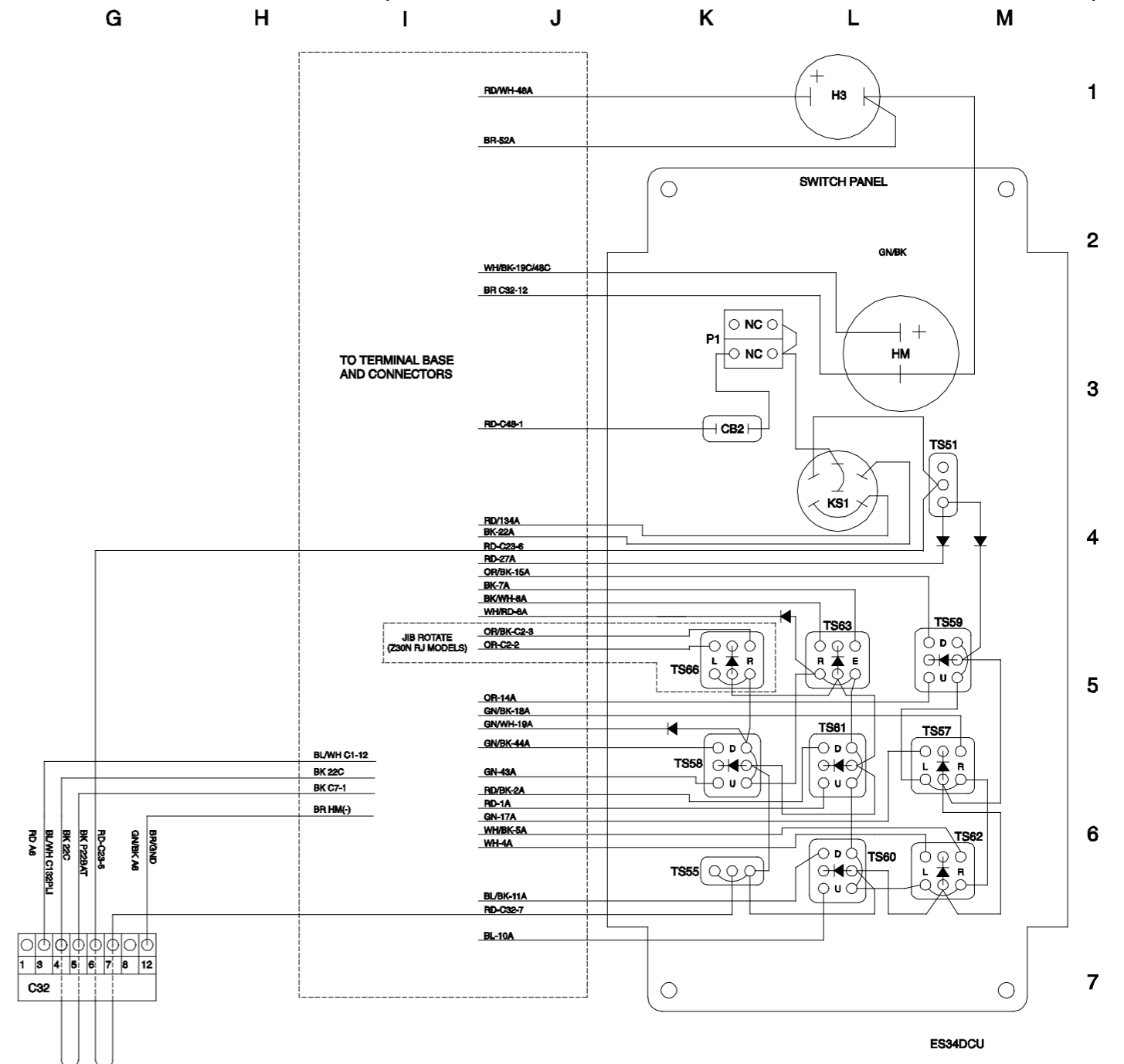
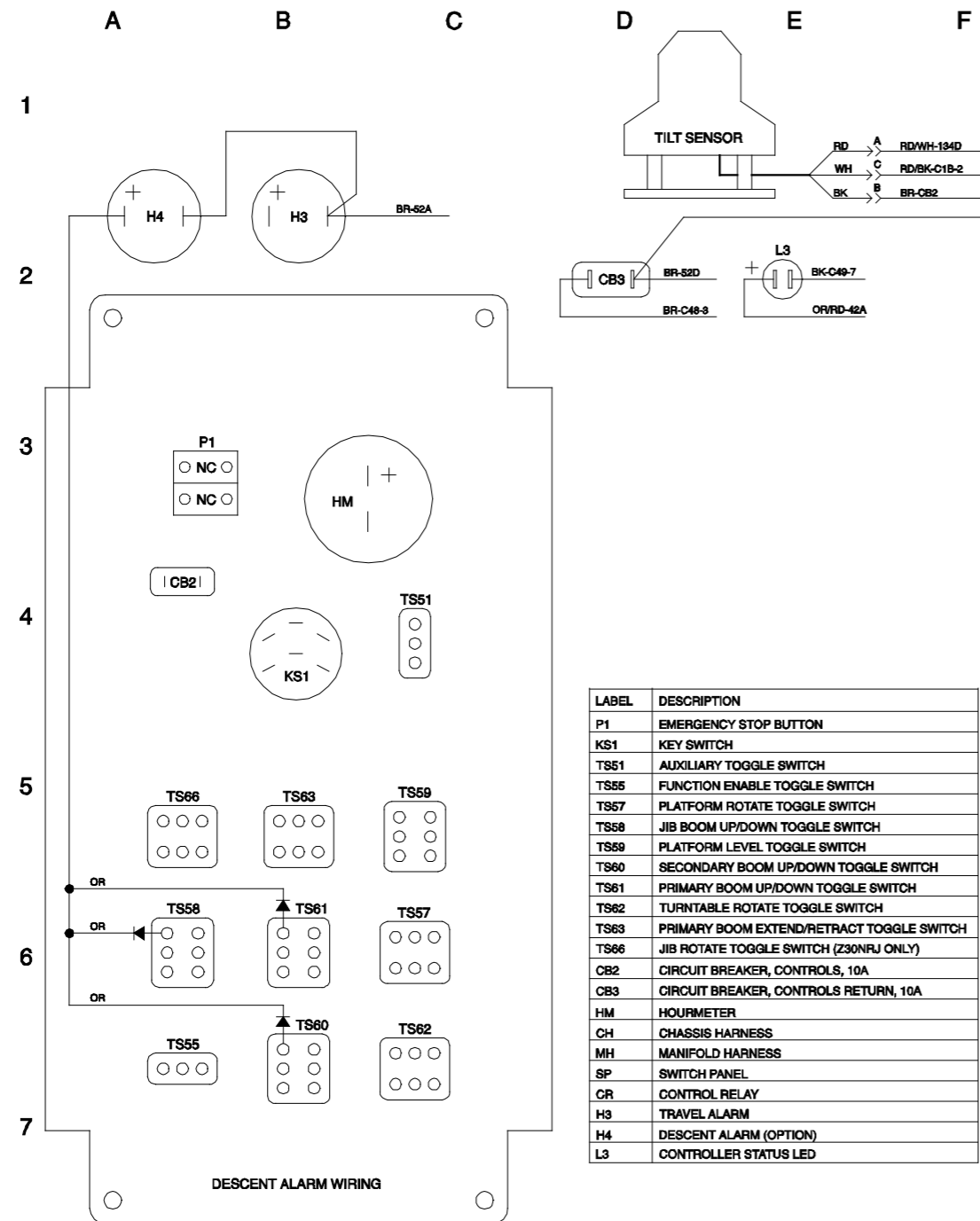

**Ground Control Box Switch Panel Wiring Diagram, (ANSI / CSA),  
(from serial numbers Z30N10-12119, Z34N10-8857 and Z3410-7774)**

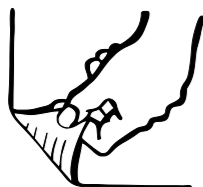

---

**Platform Control Box Wiring Diagram, (ANSI / CSA),  
(from serial numbers Z30N10-12119, Z34N10-8857 and Z3410-7774)**

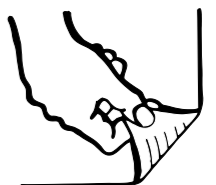

# Platform Control Box Wiring Diagram, (ANSI / CSA)

(from serial numbers Z30N10-12119, Z34N10-8857 and Z3410-7774)

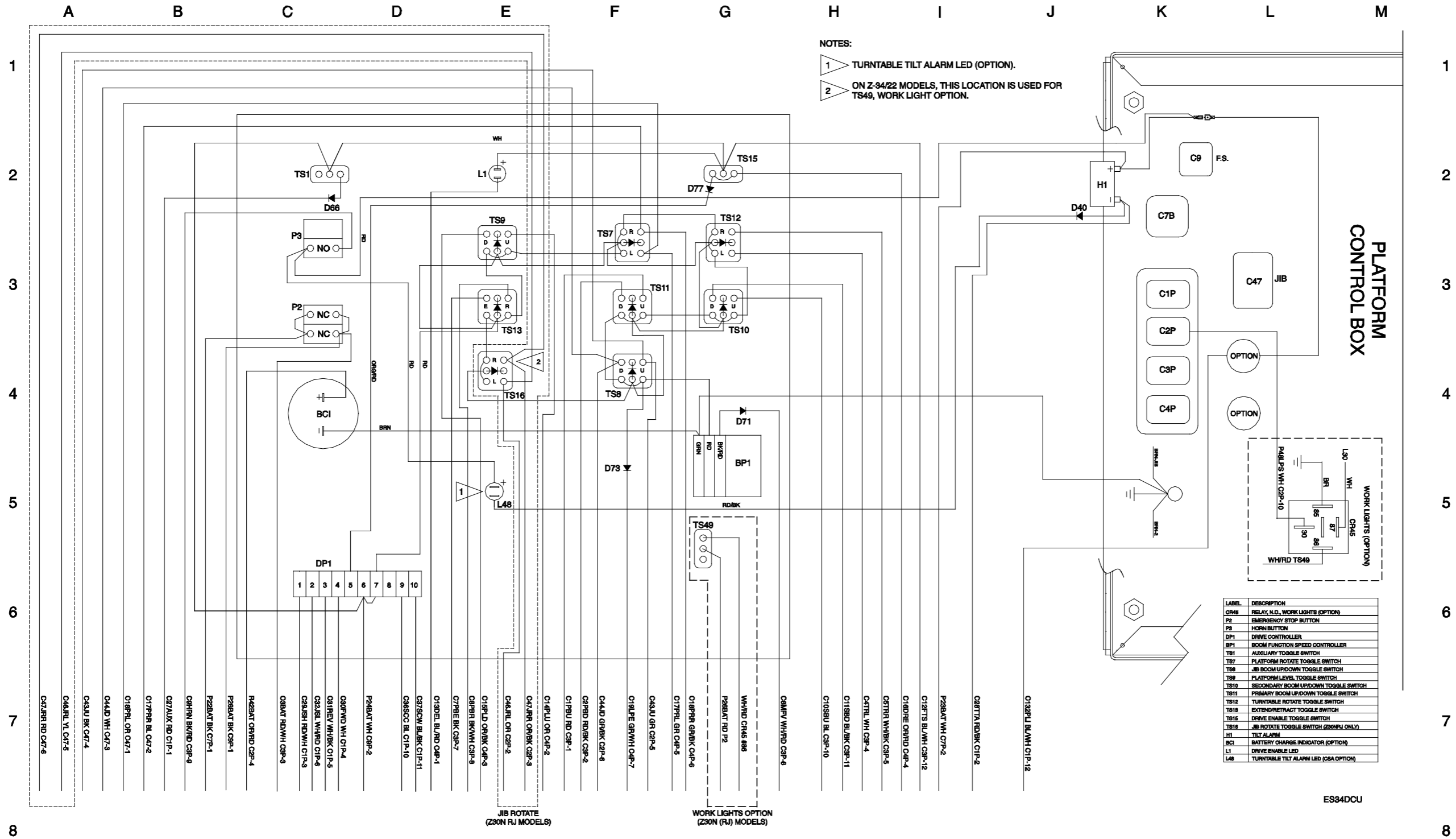



---

**Electrical Schematic, (AS / CE),  
(from serial numbers Z30N10-12119, Z34N10-8857 and Z3410-7774)**

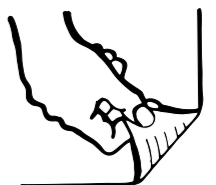

# Electrical Schematic, (AS / CE)

(from serial numbers Z30N10-12119, Z34N10-8857 and Z3410-7774)

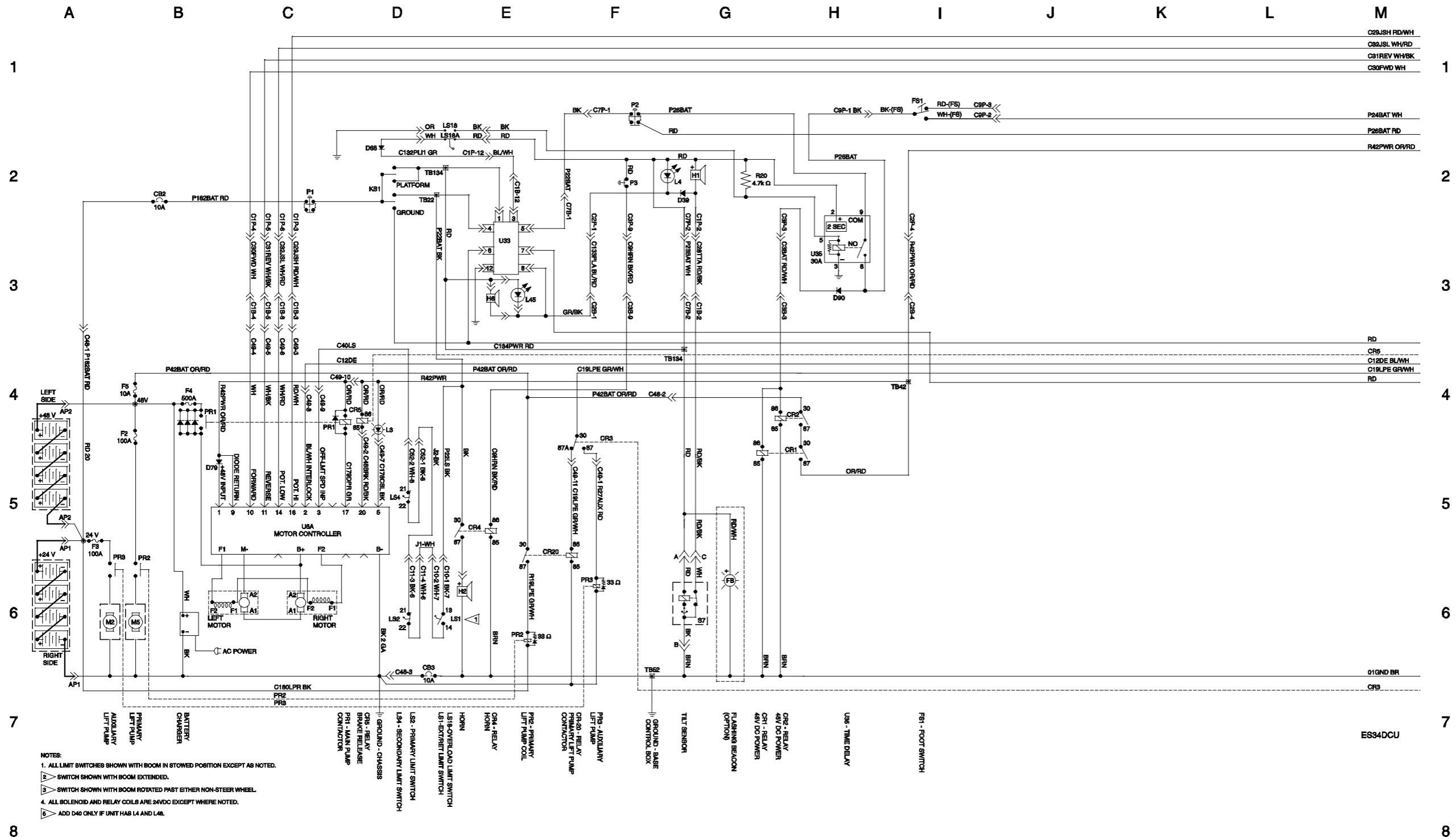

# Electrical Schematic, (AS / CE) (from serial numbers Z30N10-12119, Z34N10-8857 and Z3410-7774)

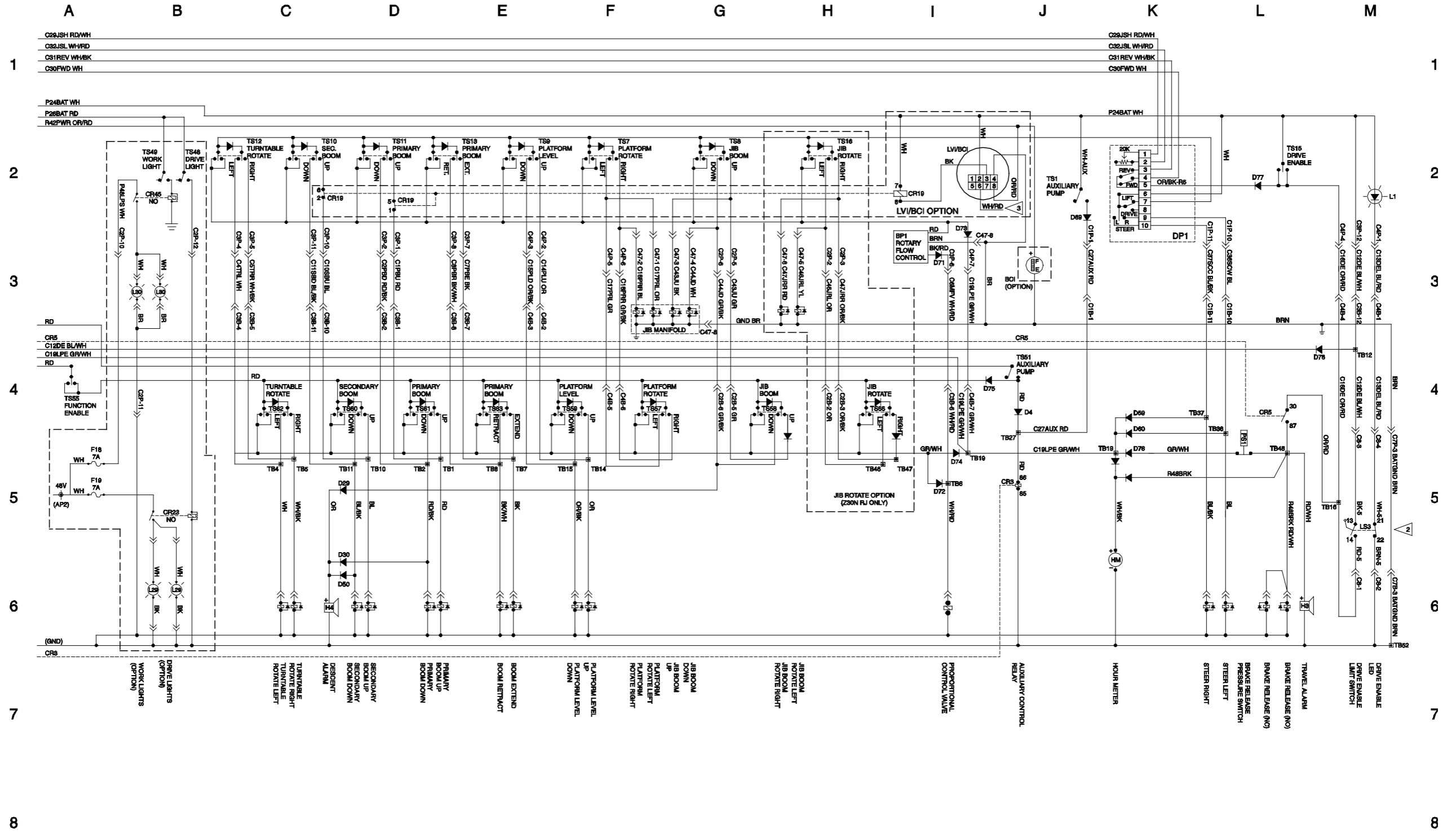

**Electrical Schematic, (AS / CE),  
(from serial numbers Z30N10-12119, Z34N10-8857 and Z3410-7774)**

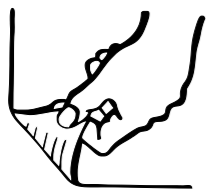

---

**Ground Control Box Terminal Strip Wiring Diagram, (AS / CE),  
(from serial numbers Z30N10-12119, Z34N10-8857 and Z3410-7774)**

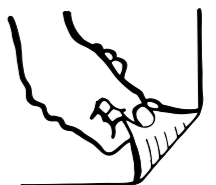

# Ground Control Box Terminal Strip Wiring Diagram, (AS / CE)

(from serial numbers Z30N10-12119, Z34N10-8857 and Z3410-7774)

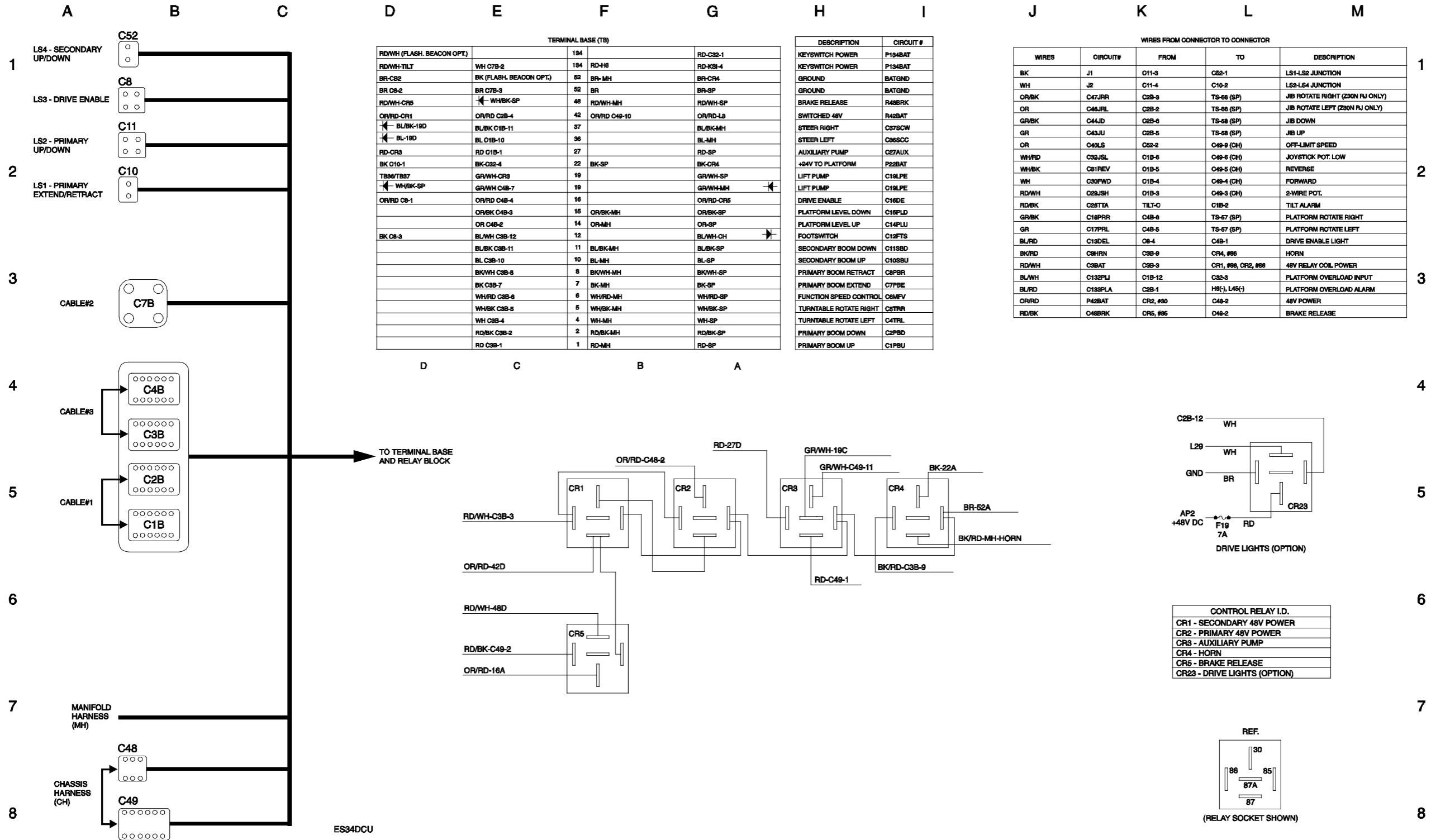

TERMINAL BASE (TB)				
RDWH (FLASH. BEACON OPT.)	WH C7B-2	194	RD-H6	RD-C82-1
RDWH-TILT	BR C82	52	BR-MH	BR-CR4
BR C82-2	BR C7B-3	52	BR	BR-SP
RDWH-CR5	WH/BK-SP	48	RDWH-MH	RDWH-SP
OR/RD-CR1	OR/RD C2B-4	42	OR/RD C4B-10	OR/RD-L8
BL/BK-19D	BL/BK C1B-11	37		BL/BK-MH
BL-19D	BL C1B-10	36		BL-MH
RD-CR3	RD C1B-1	27		RD-SP
BK C10-1	BK-C82-4	22	BK-SP	BK-CR4
TBM/TB87	GR/WH-CR3	19		GR/WH-SP
WH/BK-SP	GR/WH C4B-7	19		GR/WH-MH
OR/RD C8-1	OR/RD C4B-4	16		OR/RD-CR5
	OR/BK C4B-3	15	OR/BK-MH	OR/BK-SP
	OR C4B-2	14	OR-MH	OR-SP
BK C8-3	BL/WH C3B-12	12		BL/WH-CH
	BL/BK C3B-11	11	BL/BK-MH	BL/BK-SP
	BL C3B-10	10	BL-MH	BL-SP
	BK/WH C3B-8	8	BK/WH-MH	BK/WH-SP
	BK C3B-7	7	BK-MH	BK-SP
	WH/RD C3B-6	6	WH/RD-MH	WH/RD-SP
	WH/BK C3B-5	5	WH/BK-MH	WH/BK-SP
	WH C3B-4	4	WH-MH	WH-SP
	RD/BK C3B-2	2	RD/BK-MH	RD/BK-SP
	RD C3B-1	1	RD-MH	RD-SP

DESCRIPTION	CIRCUIT #
KEYSWITCH POWER	P134BAT
KEYSWITCH POWER	P134BAT
GROUND	BATGND
GROUND	BATGND
BRAKE RELEASE	R48BRK
SWITCHED 48V	R42BAT
STEER RIGHT	C379CW
STEER LEFT	C36SCC
AUXILIARY PUMP	C27AUX
+24V TO PLATFORM	P22BAT
LIFT PUMP	C19LPE
LIFT PUMP	C19LPE
DRIVE ENABLE	C16DE
PLATFORM LEVEL DOWN	C15PLD
PLATFORM LEVEL UP	C14PLU
FOOTSWITCH	C12FTS
SECONDARY BOOM DOWN	C11SD
SECONDARY BOOM UP	C10SBU
PRIMARY BOOM RETRACT	C8PBE
PRIMARY BOOM EXTEND	C7PBE
FUNCTION SPEED CONTROL	C6MFV
TURNTABLE ROTATE RIGHT	C5TRR
TURNTABLE ROTATE LEFT	C4TRL
PRIMARY BOOM DOWN	C2PBD
PRIMARY BOOM UP	C1PBU

WIRES FROM CONNECTOR TO CONNECTOR				
WIRES	CIRCUIT#	FROM	TO	DESCRIPTION
BK	J1	C11-3	C82-1	LS1-LS2 JUNCTION
WH	J2	C11-4	C10-2	LS2-LS4 JUNCTION
OR/BK	C47JRR	C2B-8	TS-86 (SP)	JIB ROTATE RIGHT (Z30N FJ ONLY)
OR	C46JRL	C2B-2	TS-86 (SP)	JIB ROTATE LEFT (Z30N FJ ONLY)
GR/BK	C44JD	C2B-6	TS-58 (SP)	JIB DOWN
GR	C43JU	C2B-5	TS-58 (SP)	JIB UP
OR	C40LS	C62-2	C49-8 (CH)	OFF-LIMIT SPEED
WH/RD	C32JSL	C1B-6	C49-6 (CH)	JOYSTICK POT. LOW
WH/BK	C31REV	C1B-5	C49-5 (CH)	REVERSE
WH	C30FWD	C1B-4	C49-4 (CH)	FORWARD
RD/WH	C29JSH	C1B-3	C49-3 (CH)	2-WIRE POT.
RD/BK	C28TTA	TILT-C	C1B-2	TILT ALARM
GR/BK	C18PRR	C4B-6	TS-57 (SP)	PLATFORM ROTATE RIGHT
GR	C17PRL	C4B-5	TS-57 (SP)	PLATFORM ROTATE LEFT
BL/RD	C13DEL	C8-4	C4B-1	DRIVE ENABLE LIGHT
BK/RD	C8HRN	C3B-9	CR4, #66	HORN
RD/WH	C3BAT	C3B-3	CR1, #66, CR2, #66	48V RELAY COIL POWER
BL/WH	C132PLI	C1B-12	C32-3	PLATFORM OVERLOAD INPUT
BL/RD	C138PLA	C2B-1	H8(-), L45(-)	PLATFORM OVERLOAD ALARM
OR/RD	P42BAT	CR2, #80	C4B-2	48V POWER
RD/BK	C48BRK	CR5, #66	C4B-2	BRAKE RELEASE

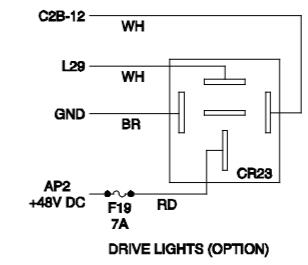
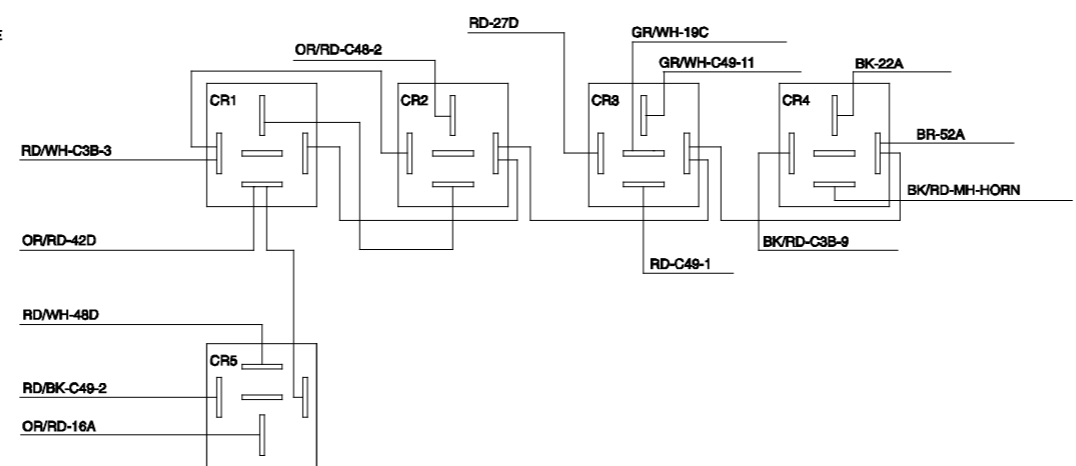

CONTROL RELAY I.D.	
CR1	SECONDARY 48V POWER
CR2	PRIMARY 48V POWER
CR3	AUXILIARY PUMP
CR4	HORN
CR5	BRAKE RELEASE
CR6	DRIVE LIGHTS (OPTION)

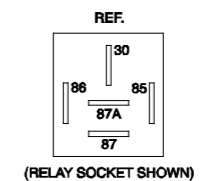

### Ground Control Box Switch Panel Wiring Diagram, (AS / CE) (from serial numbers Z30N10-12119, Z34N10-8857 and Z3410-7774)

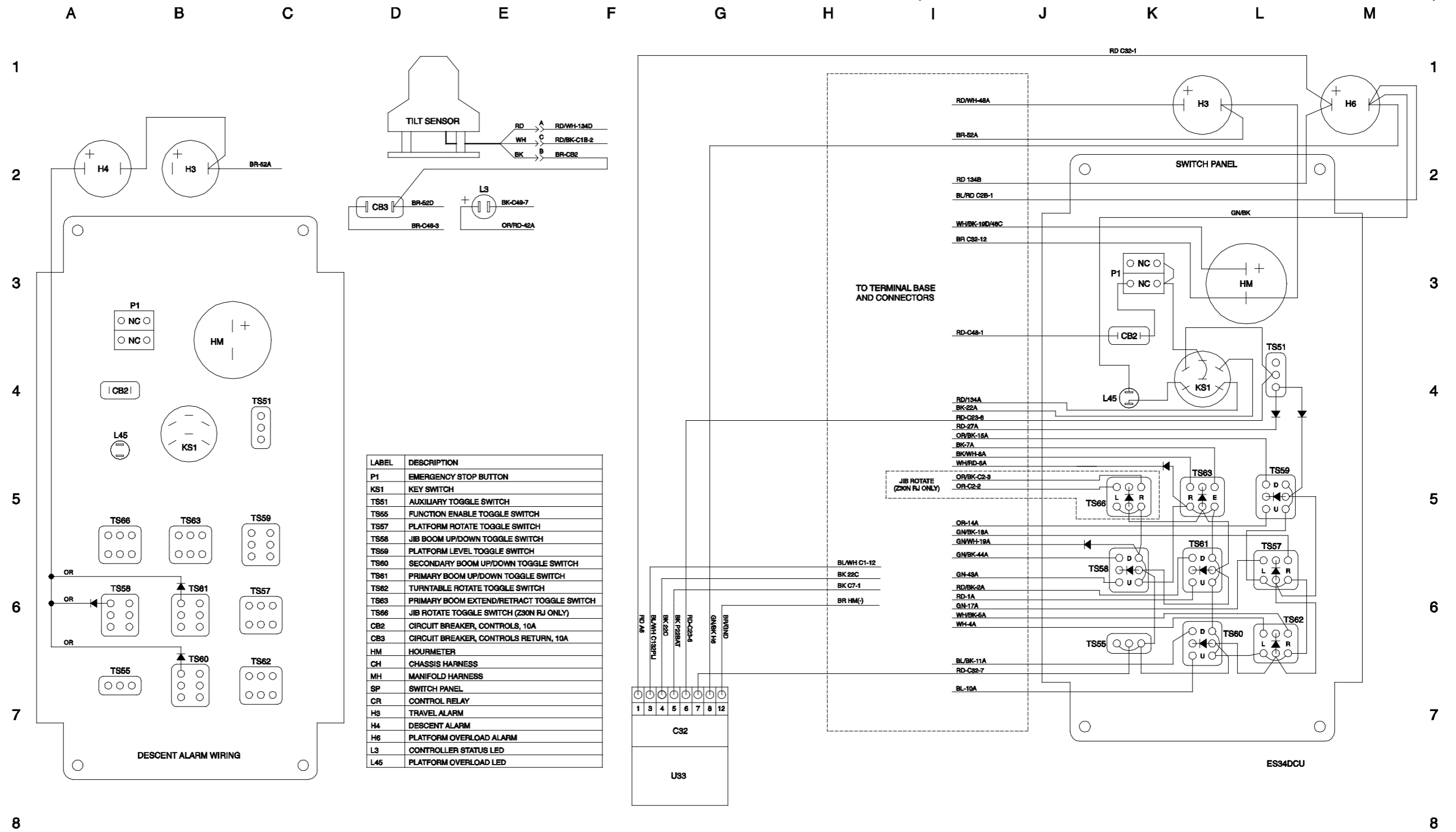

**Ground Control Box Switch Panel Wiring Diagram, (AS / CE),  
(from serial numbers Z30N10-12119, Z34N10-8857 and Z3410-7774)**

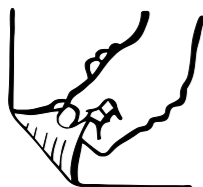



---

**Platform Control Box Wiring Diagram, (AS / CE),  
(from serial numbers Z30N10-12119, Z34N10-8857 and Z3410-7774)**

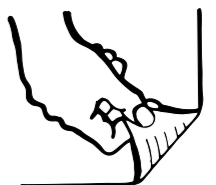

# Platform Control Box Wiring Diagram, (AS / CE)

(from serial numbers Z30N10-12119, Z34N10-8857 and Z3410-7774)

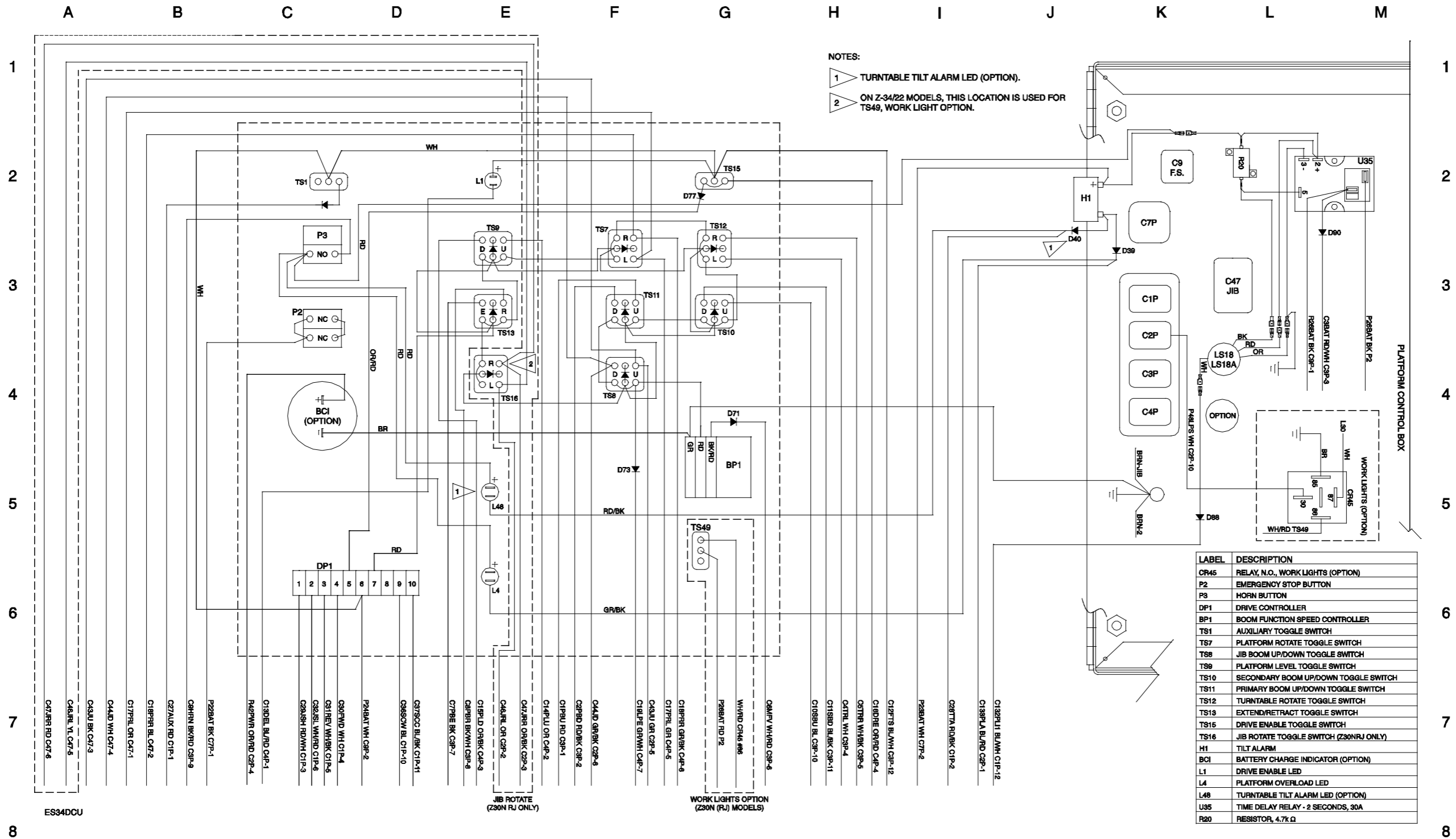

---

**Genie Scandinavia**  
Phone 0046 3157 5154  
Fax 0046 3157 5104

---

**Genie France**  
Phone 0033 237 260 986  
Fax 0033 237 260 998

---

**Genie Iberica**  
Phone 0034 935 725 090  
Fax 0034 935 725 080

---

**Genie Germany**  
Phone 0800 180 9017  
Phone 0049 4221 491 821  
Fax 0049 4221 491 820

---

**Genie U.K.**  
Phone 0044 1476 584 333  
Fax 0044 1476 584 330

---

**Genie Mexico City**  
Phone +52 55 5666 5242  
Fax +52 55 5666 3241

---

**Genie North America**  
Phone 425.881.1800  
Toll Free USA and Canada  
800.536.1800  
Fax 425.883.3475

---

**Genie Australia Pty Ltd.**  
Phone +61 7 3456 4444  
Fax +61 7 3375 1002

---

**Genie China**  
Phone +86 21 53853768  
Fax +86 21 53852569

---

**Genie Singapore**  
Phone +65 67533544  
Fax +65 67533544

---

**Genie Japan**  
Phone +81 3 6436 2020  
Fax +81 3 5445 1231

---

**Genie Korea**  
Phone +82 2 558 7267  
Fax +82 2 558 3910

---

**Genie Brasil**  
Phone +55 11 4082 5600  
Fax +55 22 4082 5630

---

**Genie Holland**  
Phone +31 183 581 102  
Fax +31 183 581 566

Distributed By: